

OWNER'S MANUAL



STANDARD BELT POWER TURN CONVEYORS

PORTEC, INC.
FLOMASTER® DIVISION
P.O. BOX 589
CAÑON CITY, COLORADO 81215-0589 USA
Telephone: (719) 275-7471
Fax: (719) 269-3750
e-mail: portec@portec-mhg.com

Conveyor Location: _____

Model Number: _____

Serial Number: _____

MAINTENANCE AND INSPECTION

- Applications suggestions
- Installation instructions
- Belt adjustment
- Belt replacement
- Chain tension adjustment
- Troubleshooting
- Parts list
- Warranty

NOTICE

- Make sure ALL guards are in place before operating machine.
- Make sure power is off before working on machine.
- Keep hands and loose clothing away from drive components while machine is in operation.

Table of Contents

I.	General Description of Portec Power Turns	1
II.	Product Safety Precautions	1
III.	Installation Instructions	2
A.	Assembly & Setup: Conveyors with multi-section frame	2
B.	Assembly & Setup: Conveyors with one-piece frame	4
IV.	Service and Maintenance	6
A.	Visual check	6
B.	Fasteners	6
C.	Chain & sprockets	6
1.	Chain tension	6
2.	Sprocket alignment	9
3.	Sprocket set screws and taper lock hubs	10
D.	Chain connecting link	11
E.	Attachment links	11
F.	End rolls	13
G.	Wear strips	14
H.	Conveyor belts	17
1.	Belt replacement (laced seams on both ends)	17
2.	Belt replacement (vulcanized endless belt and removable inside radius frame)	18
3.	Belt replacement (vulcanized endless belt on larger conveyors without removable inside radius frame)	19
I.	Return Rolls	20
J.	Lubrication	20
K.	Preventive Maintenance Schedule	22
V.	Drive Unit	23
VI.	Product Data Sheets	24
VII.	Troubleshooting Guide	25
VIII.	Spare Parts	26
A.	Recommended spare parts list for power turns	26
IX.	Parts List – Flomaster Power Turns	27
X.	Illustrated Parts Diagram	29
XI.	Warranty	30
	Flomaster’s Customer Service Department	31
	Expanded Warranty Coverage	31
	Installation Field Service	32
	Preventive Maintenance Field Service	33
	Flomaster Maintenance Training	34

I. General Description of Portec Power Turns

The belt power turn was invented by the Fry brothers in Cañon City, Colorado in the 1950's. Their company later became the Flomaster Division of Portec, Inc. Since 1958, the Flomaster Division has built over 50,000 belt power turns to satisfy the material handling needs of a wide range of industries. No company has more experience building the highest quality belt power turns than Portec Flomaster. A Portec belt power turn is the most reliable, longest lasting belt power turn available anywhere in the world.

The belt on a Flomaster belt power turn is positively driven by a chain that is attached to the outside perimeter of the belt. This positive drive arrangement is unaffected by changes in loading, temperature, humidity, and foreign matter getting between the bottom of the belt and the end rolls. Because high belt tension is not required, components last longer for more reliable service.

II. Product Safety Precautions

- A. Disconnect the power and perform the appropriate lock-out/tag-out procedures before performing maintenance or service work.
- B. All guards must be in place at all times during operation.
- C. Ensure that no objects are rubbing against the conveyor belt.
- D. No loose clothing should be worn when standing near an operating conveyor.
- E. Never lift a conveyor by the drive shaft extension.
- F. Do not adjust the end rolls to minimize the transfer distance to an adjoining conveyor.
- G. Do not adjust the end roll so that the belt is tight against it.
- H. Install the connecting link clip with the open end opposite the direction of belt travel.
- I. Maintain all sprocket to chain alignments.
- J. Maintain adequate chain lubrication.
- K. Do not stand or place any heavy weight on the drive components, chain cover or sideguards.

III. Installation Instructions

Power turn conveyors are normally shipped partially disassembled. The drive unit, floor supports, and sideguards will have to be attached to the conveyor. Larger-sized conveyors are sometimes shipped in sections and will have to be assembled in the field.

A. Assembly & Setup: Conveyors with multi-section frame

1. Remove the crate top and all parts bags and accessories from inside the crate. Inventory all parts that are not connected to the conveyor. Contact the shipping carrier immediately if shipping damage is suspected.
2. Remove the crate sides and unbolt the conveyor from the floor of the crate.

Note: Do not lift a conveyor by the drive shaft extension as this will cause severe shaft deflection.

3. Raise one end section and attach the floor supports and braces.
4. While supporting the end section in place, raise the next section and bolt it to the end section using the pre-drilled plates below the slider bed and on the lower side of the frames. (Portec does not recommend attempting to lift a large conveyor in one piece due to potential damage to the conveyor at the joints between sections.)

Note: Use a straight edge to ensure that the slider bed is flat at the joints. A slight step down situation in the direction of the belt travel is permissible. A step-up situation in the direction of the belt travel will cause damage to the belt and lacing.

(Refer to Figure 1)

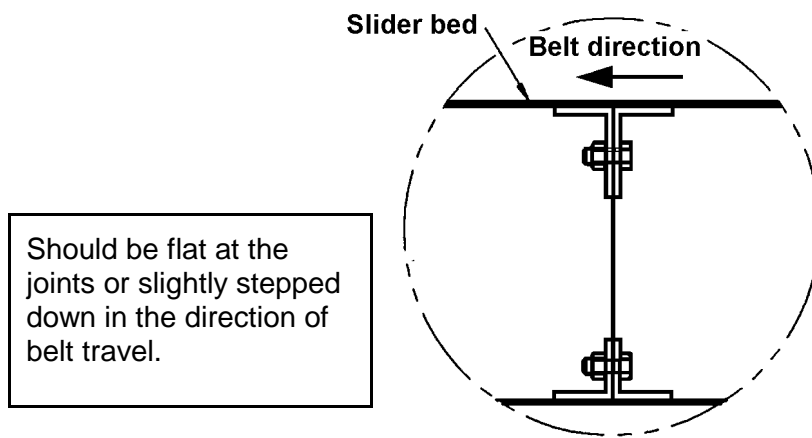

Figure 1

5. After bolting together the remaining end piece, the remaining floor supports and braces should be attached using the bolts provided.
6. After the frame is assembled and floor supports attached, position the conveyor in relation to the adjoining conveyors. Level the conveyor and securely attach to the floor. It may be necessary to shim the legs if the floor is uneven.
7. Apply a 1/4" (6 mm) bead of Lubriplate Molith #2 grease in the groove of each vertical wear guide for the length of the conveyor.
8. Install the belt and chain on the conveyor and connect the chain using the special connecting link provided, and connect the belt lacing using the lacing pin provided. Install the connecting link clip with the open end opposite to the direction of belt travel. (Refer to Figure 2)

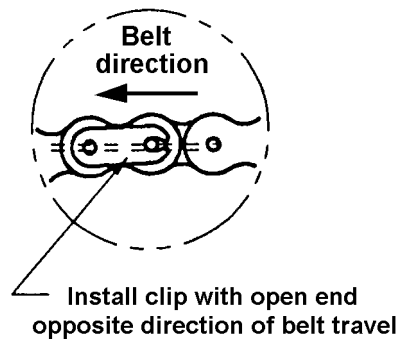

Figure 2

9. Inspect the chain tension after set up. To adjust the chain tension, move the outside radius end roll bearing assembly until the chain, as it leaves the discharge end sprocket, has a slight sag as it enters the entry end lower chain guide. The chain sag (slack) should be no less than 1/8" or more than 3/8" (3.2 – 9.6 mm). (Refer to Figure 3)

Warning: Do not adjust the end rolls to minimize the transfer distance to an adjoining conveyor. Either move the entire conveyor or use a transfer roll to minimize the transfer distance.

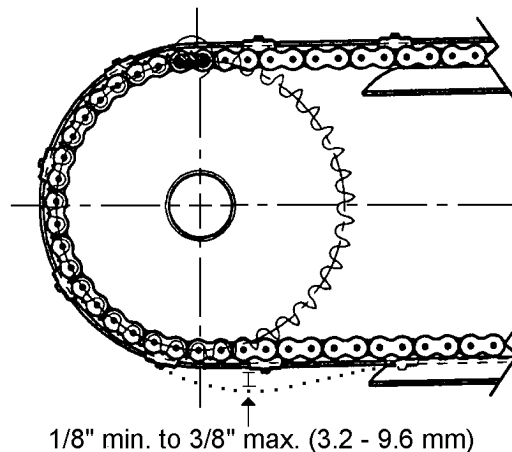

Figure 3

10. Mount the drive. (Refer to the drive mounting instructions provided with the conveyor.)
11. During the initial run-in period, listen for any unusual noises and observe the belt to ensure that it is not rubbing any part of the conveyor, sideguards, chain cover, or an adjoining conveyor. Some small adjustments may be necessary and are described in further detail in this manual. The first check should be made after the first 40 hours of operation. (See the Preventive Maintenance Schedule)

Note: Do not stand or place any heavy weight on the drive components, chain cover, or sideguards.

B. Assembly & Setup: Conveyors with one-piece frame

Portec power turn conveyors with a one-piece frame have been fully assembled, adjusted, and shop tested before being shipped. Only minor checking is required to ensure that no parts may have shifted during shipment. The floor supports, sideguards, and drive unit are normally removed for shipment. After uncrating the conveyor and moving it to the site, the assembly process may begin.

1. Raise the conveyor and attach the floor supports and braces using the bolts provided. Be sure to observe all safety precautions when working under hoisted equipment.

Note: Never lift a conveyor using the drive shaft. This will bend the drive extension.

2. Position the conveyor in relation to the adjoining conveyors. Level and securely attach the conveyor to the floor. It may be necessary to shim the legs if the floor is uneven.

3. Mount the drive unit. (Refer to the drive mounting instructions supplied with the conveyor.)
4. Before startup, check to be sure that the belt is not rubbing against any part of the conveyor, sideguard, chain cover, or an adjoining conveyor.
5. Inspect the chain tension after setup. Attempt to maintain the initial chain tension when making future adjustments. The first check should be made after the first 40 hours of operation. (See the Preventive Maintenance Schedule)

Note: *Future adjustments to allow for chain stretch must be done, taking care not to bring the belt tight against the roll.*

WARNING: A CONVEYOR THAT IS ADJUSTED WITH THE BELT TIGHT AGAINST THE ROLL MAY DAMAGE THE EQUIPMENT AND BECOME HAZARDOUS.

IV. Service and Maintenance

Warning: **Disconnect the power and perform the appropriate lock-out/ tag-out procedures.**

- A. Visual check:** Check for any changes, rub marks, abrasion, noises, excessive dust, or damage to the belt. The belt must be relatively clean and gouge free. The belt seams should be in good condition with no evidence of damage or excessive wear. The chain should be adjusted so it is snug, not tight. The belt should never be tight against the end roll, or damage to the conveyor may result. (See Figure 9)
 - 1. Turn on the conveyor and visually check that the chain that is attached to the belt makes a smooth transition from the wear strips to the sprocket. Listen for chain chatter and watch for uneven chain movement. Make adjustments as necessary.
 - 2. Check that all guards and safety devices are in place.
- B. Fasteners:** Inspect all fasteners to be sure they are tight.
- C. Chain & sprockets**
 - 1. **Chain tension:** Excessive chain rattling or rumbling as the chain engages the sprockets is an indication that the chain is incorrectly tensioned. Chain looseness will possibly develop in a new Portec power turn during the run-in period due to the seating of the chain in the wear guide material and normal elongation of the chain. Chain elongation most often appears after extended operation. Chain tension may be adjusted as follows:
 - a. Remove the chain cover to reveal the chain and sprocket. Be careful not to bend or distort the chain cover when removing. Check the alignment of the sprockets. (Refer to sprocket alignment instructions.)

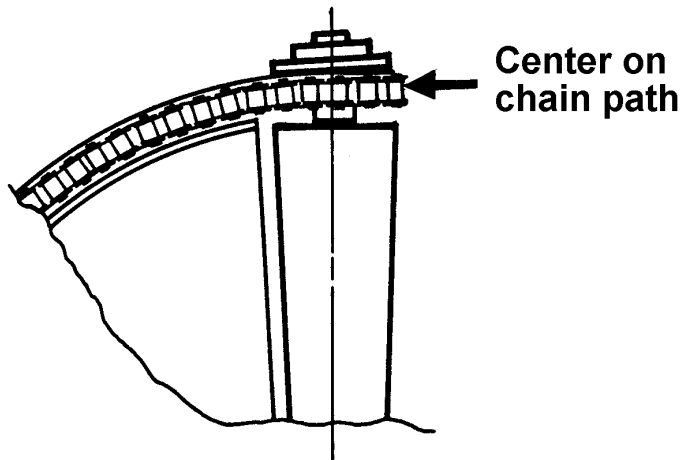
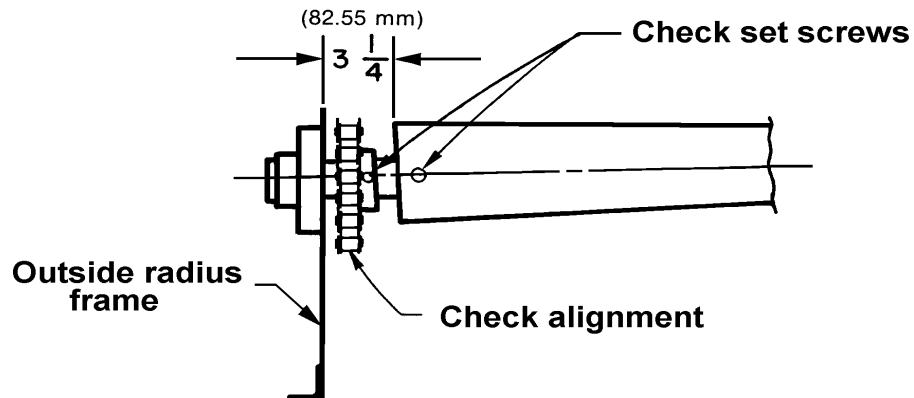

Figure 4

Note: Misalignment can cause premature chain and sprocket wear or cause the chain to jump the sprocket teeth.

- b. Check the sprocket set screws to ensure that they are tight. (Refer to Figure 5)

Note: If the sprocket or end roll has a taper lock hub, a long-handled hex wrench will be required to reach the screws in the bushing. The taper lock bushing in the sprocket requires a long-handled hex wrench with a shortened end. The taper lock bushing in the end roll requires a long-handled hex wrench that is bent slightly to clear the end roll.



SET SCREWS IN SPROCKETS AND TAPERED ROLLS

Figure 5

- c. Adjust the chain tension by moving the outside radius end roll bearing assembly until the chain, as it leaves the discharge end sprocket, has a slight sag as it enters the entry end lower chain guide. While running, the chain sag (slack) should be no less than 1/8" or more than 3/8" (3.2 – 9.6 mm). (Refer to Figures 6 & 7)

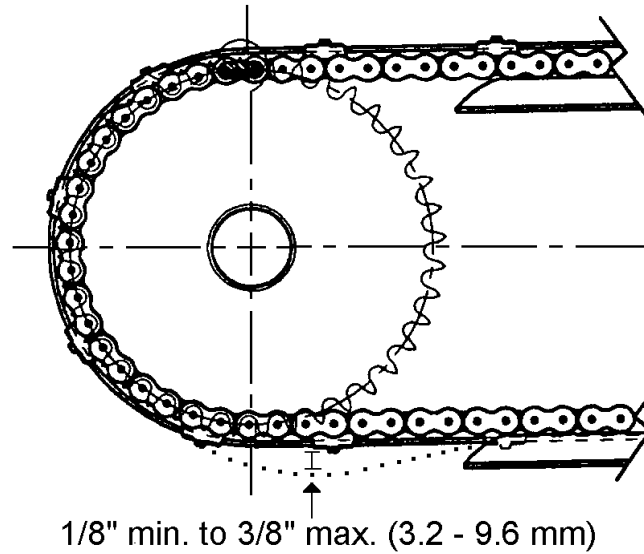

Figure 6

Chain Adjustment

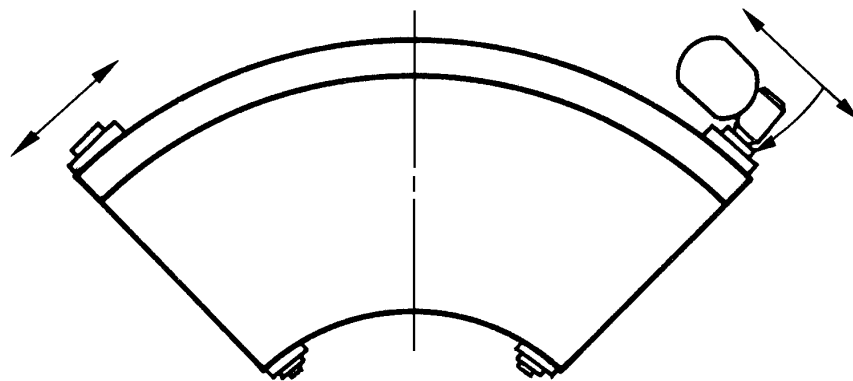

Figure 7

- d. Before final tightening of the bearing bolts, check the alignment of the end roll with the slider bed.

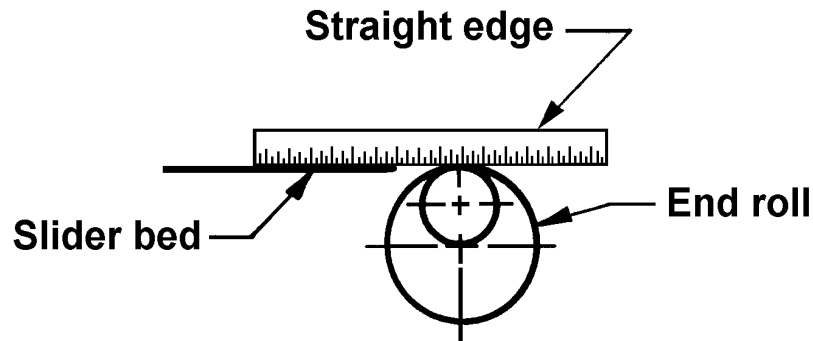
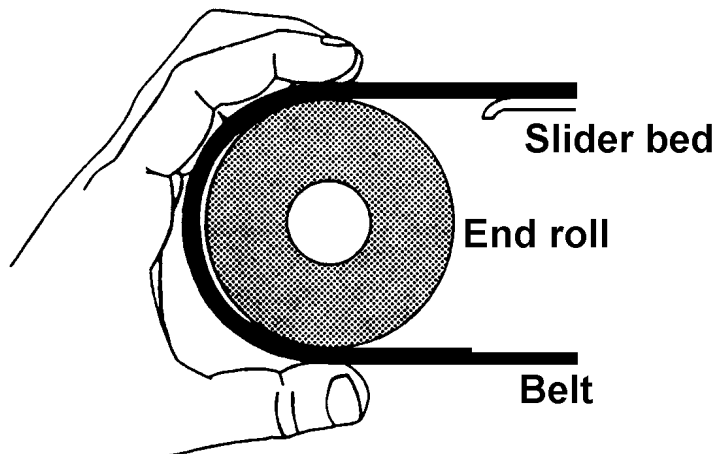

Figure 8

- e. Check the belt tension at the inside radius end of the end roll to ensure that the belt is not snug against the end roll. Squeeze the belt on the end roll and pull slightly. There should be a gap of $1/16'' - 1/8''$ (1.6 - 3.2 mm) between the belt and the end roll. (See Figure 9)
- f. Replace chain cover.



Squeeze and pull --- $1/16''$ to $1/8''$ gap

Figure 9

2. **Sprocket alignment:** (See Figure 4) The sprocket should be centered in the chain path. Sprockets that are out of alignment can cause

premature wearing of the chain, sprockets, and wear strips. Rattling, ticking or rumbling of the chain as it passes over a sprocket may indicate that the sprocket is out of alignment. As the chain wear strips wear down, the position of sprockets may have to be adjusted to accommodate the new chain path.

- a. When adjusting the position of the sprocket that is equipped with a set screw hub, the sprocket should be loosened on the shaft and then moved to the correct position. The entire end roll assembly should be moved when the sprocket is equipped with a taper lock hub.

3. Sprocket set screws and taper lock hubs:

- a. **Steel sprocket with plain bore:** A Nylock socket set screw with a cupped point is used at keyway locations and a Nylock set screw with a half dog point is used at all other positions. It is extremely important that these different types of set screws not be interchanged in different locations because of their different locking functions.
- b. **Loosening taper lock hub bushings from steel sprockets:** (See Figure 10) Remove the set screws and insert one into the hole which is threaded in the bushing only, using it as a jack screw. This will disengage the bushing for removal.
- c. **Tightening taper lock hubs in steel sprockets:** Insert both set screws in opposing half thread holes with the bushing hole pattern matching the hub pattern. Alternately tighten both set screws. Lightly tap the bushing to ensure proper seating and re-tighten both set screws.

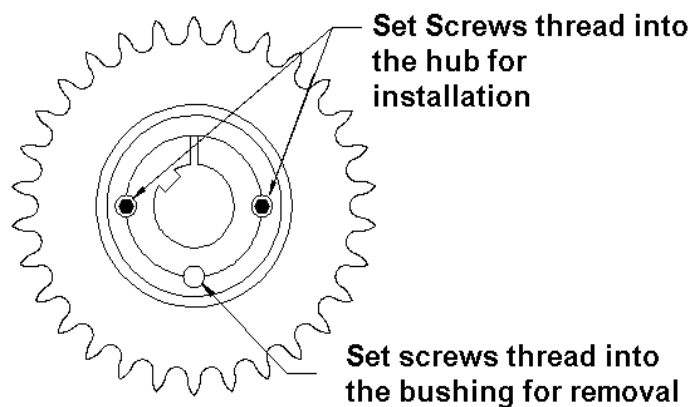

Figure 10

Recommended Installation Wrench Torque

Bushing No.	Lb. In.	Nm
1610	175	19,9
2012	280	31,8
2517	430	48,8

- D. Chain connecting link:** The chain connecting link on a Portec Power Turn was designed to be used with sidebow chain. The chain is allowed to flex in order to bend around the curve. When installing the connecting link, ensure that the open end of the clip is opposite the direction of belt travel. (See Figure 11)

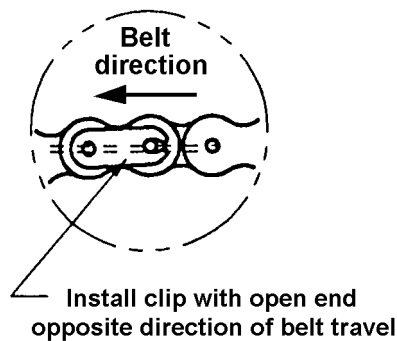
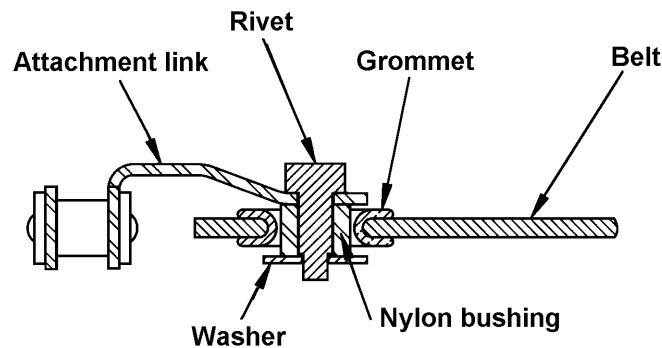

Figure 11

- E. Attachment links:** (See Figure 12) An attachment link is used to attach the sidebow chain to the outside edge of the curved belt. If the attachment link is damaged, it may be replaced as follows:
- Remove the chain cover.
 - Move belt assembly until the damaged attachment link is on the top of the conveyor.



Cross section of belt w/hardware

Figure 12

- c. Loosen the belt tension by loosening the outside radius end roll bearing bolts on the non-drive end.
- d. Lift up the drive chain out of the wear guide track and “break” the chain on each side of the damaged attachment link.
- e. Bend the edge of the belt over and grind off the rivet that holds the attachment link to the belt and remove the damaged attachment link. **Be careful not to contaminate the grease in the wear guide track with metal particles or damage the belt with the grinder.**
- f. Install a new attachment link into the chain using two connecting links. Ensure that the connecting link clip is in the proper direction in relation to the belt direction. (See Figure 11)
- g. Inspect the condition of the grommet in the belt. Replace if it is worn or damaged.
- h. Connect the new attachment link to the belt using a new rivet, washer, and nylon bushing. Place a heavy piece of metal under the rivet when peening the rivet onto the top of the washer. The rivet end should be peened enough to securely attach the washer while not allowing the washer to rotate on the bottom of the rivet. **Care should be used during the peening process to prevent damage to the belt or the top of the conveyor slider bed.**

Note: A threaded cap screw and rivet are available through the Portec parts department, which will eliminate the peening process; however, Loctite® **must** be used on the threads to keep the assembly together.

- i. Lay the chain back into the wear guide track.

- j. Adjust the chain tension and tighten the outside radius bearing bolts. (See Chain Adjustment–Figure 6)
 - k. Replace the chain cover.
- F. End rolls:** A tapered end roll is used to accommodate the difference in belt speeds from the inside radius to the outside radius of the turn. End roll lagging is not required because the conveyor belt is powered by the outside perimeter chain and not by the end roll. When properly aligned and fastened to the drive shaft, it is rare for the end roll to require replacement.
- 1. **Alignment:** The end roll alignment can be adjusted as follows:
 - a. Remove the chain cover
 - b. Refer to Figure 13 to check the position of the roll in relation to the sprocket and chain guide.
 - c. Move the belt assembly around until the laced belt seam and chain-connecting link is on the top side of the conveyor near the end roll that needs to be adjusted.
 - d. Remove the chain-connecting link and pull out the belt-lacing pin. Lay the end of the belt back to expose the end roll.
 - e. Loosen the set screws that secure the end roll to the drive shaft. (See Figure 10)
 - f. Adjust the position of the end roll on the shaft and re-tighten the set screws.
 - g. Reattach the belt ends and chain-connecting link.
 - h. Replace the chain cover.

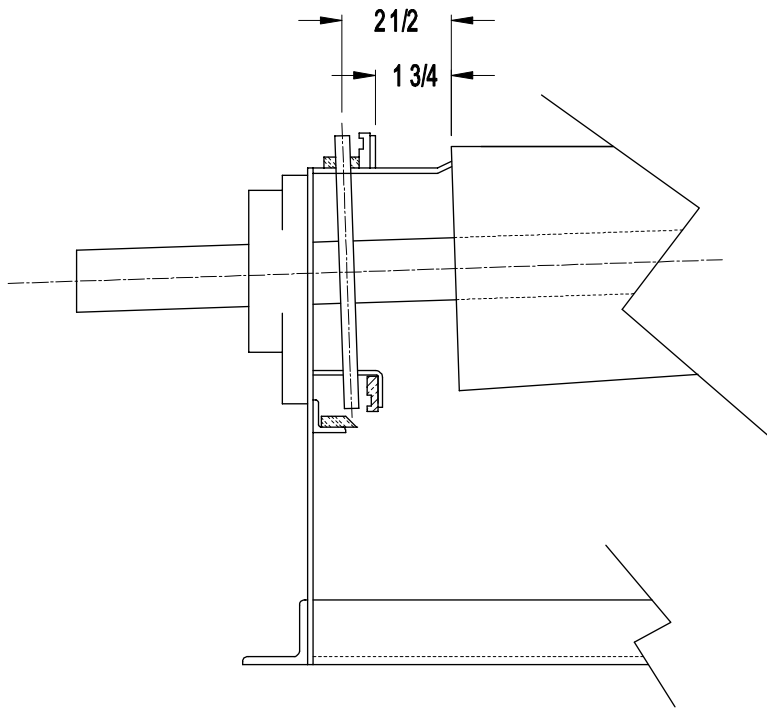

Figure 13

G. Wear strips: The belt drive chain is held in place on the outside radius via wear strips which are attached to metal guides. When properly maintained, the wear strips will provide many years of service.

1. If the wear strips are damaged or excessively worn, they may be replaced as follows: (See figure 14)
 - a. Remove the chain cover.
 - b. Remove the belt and chain assembly.

Note: Endless belts may be left on the conveyor by loosening the belt tension enough to lift the chain out of the wear strips on the top side. After removing the chain connecting link, the belt assembly may be rotated around the conveyor with the chain ends held slightly apart to allow the chain to be removed from the lower strips.

- c. Remove the old wear strips and fasteners. Take note of the positions and shapes of the old wear strips.

Note: Some older power turns had wear strip material mounted in the chain cover. Because this wear strip does not contact the chain, it does not need to be replaced.

- d. The lower horizontal strip with a 45° edge must be installed using self-tapping screws (provided).

Note: When butting pieces end to end, use a fastener near the end of both pieces and bevel the ends.

- e. The lower vertical strip must be set to the 1 ¼" dimension and attached with self-tapping screws (provided).
- f. The upper vertical guide sits on the bed and is held in place with 4d finish nails (provided) acting as pins. The notch is positioned as shown (See Figure 14). The head of the nails should be set slightly recessed, and the excess pin material should be snipped off if it extends beyond the metal backing after the horizontal piece is installed.
- g. The upper horizontal guide lies flat on the bed and is positioned against the vertical guide. It is attached with 1/8" countersunk pop rivets (provided). The rivet head should not protrude above the guide strip.
- h. Reinstall the belt and chain assembly.
- i. Lubricate the chain and reset the chain tension. (Refer to Service and Maintenance section "C" – page 6)
- j. Check the position of sprockets to ensure that they are in the center of the chain path. (Refer to Service and Maintenance section "C," # 2 – page 9)
- k. Replace the chain cover.

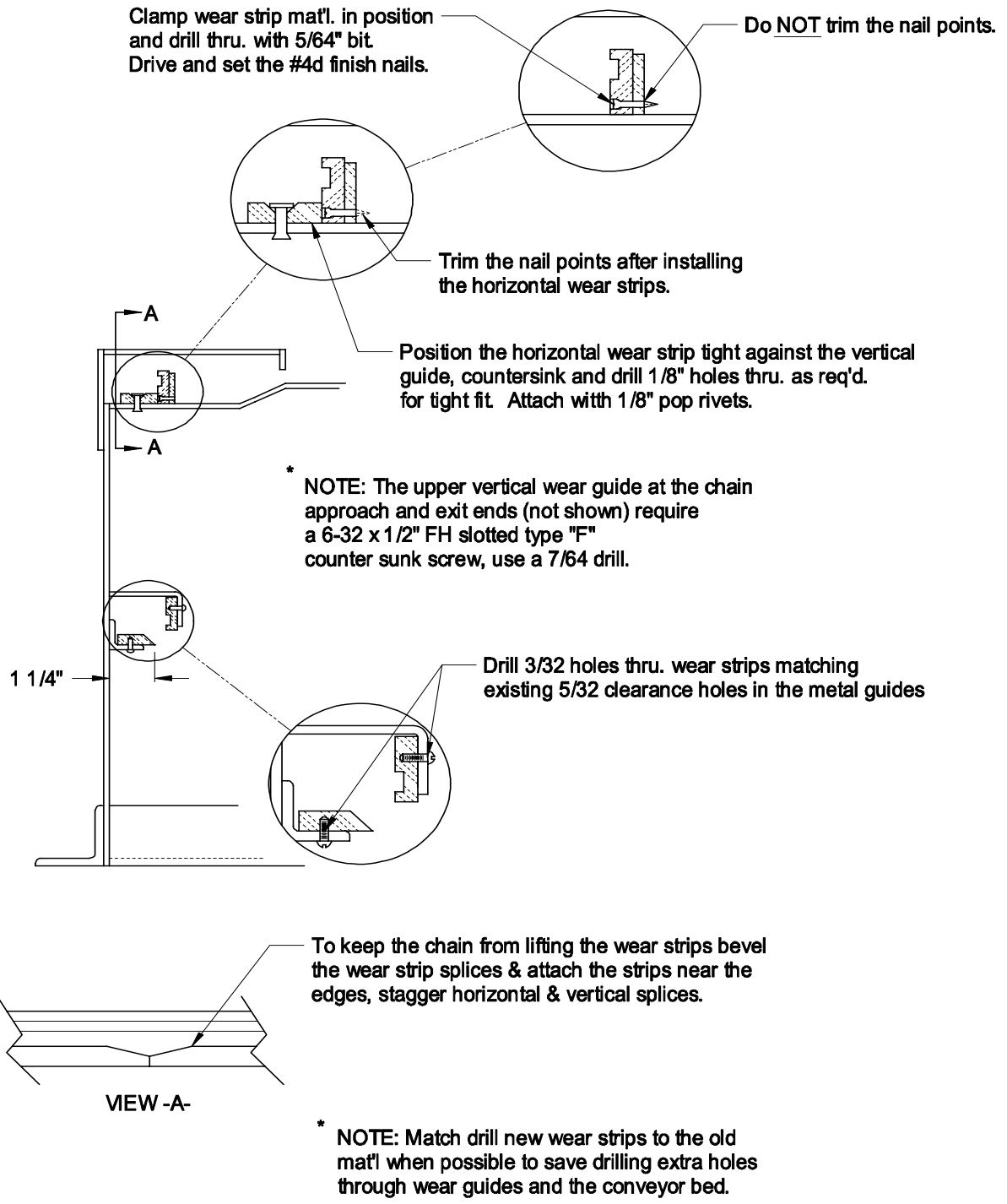

Figure 14

H. Conveyor belts: The conveyor belt on a Portec Belt Power Turn is powered by a chain that is attached to its outside edge. The chain-powered belt does not rely on friction between the end roll and the bottom of the belt, so the end roll should not be tight against the belt. The belt and chain assembly has a positive direct drive system that is not affected by loading or environmental conditions. While the system is rugged and reliable, a few adjustments will keep the conveyor operating well for many years.

- 1. Belt replacement (laced seams on both ends):** If the belt becomes worn or damaged, it may be replaced as follows:

Warning: **Do not attempt to power the new belt onto the conveyor. This will damage the wear guides and is extremely dangerous.**

- Remove the chain cover.
- Disconnect the drive unit by removing the gear reducer (shaft-mounted reducer) or removing the chain between the drive shaft and gear reducer (chain or belt driven units).
- Move the belt assembly until the chain connecting link is on the top side of the conveyor.
- Loosen all end roll bearing mounting bolts and slide the end roll assemblies to their minimum adjustment positions.
- Remove the chain connecting link and the seam lacing pin next to the end of the chain.
- Place the new belt assembly on the conveyor and attach one end of the new belt to the end of the old belt by installing a connecting link and lacing pin. As the old belt is pulled off the conveyor, the new belt will be pulled over the end roll and underneath the conveyor. As the end of the new belt is pulled around the second end roll, it may be disconnected from the old belt.
- Pull both ends of the chain together in the chain wear guides and attach the special connecting link. Standard roller chain links will not fit properly and will tend to work loose or stiffen the chain.

Note: The connecting link clip must be placed on the outer side of the chain with the open end facing away from the direction of travel. (See Figure 11)

- Lay both belt ends together and install the lacing pin. The last two or three lacing hooks on the outside radius end should be crimped down on the lacing pin. Pull slightly on the inside radius end of the lacing pin and crimp the last two or three lacing hooks on the inside radius end of the seam. Trim off the excess lacing pin.

- i. Adjust the chain tension by moving both end roll assemblies until the chain, as it leaves the discharge end sprocket, has a slight sag as it enters the entry end lower chain guide. The chain sag (slack) should be no less than 1/8" or more than 3/8" (3.2 – 9.6 mm). The inside radius end of the end rolls should remain loose. (See Figures 6 and 9)
- j. Adjust the belt tension on the inside radius. (See Figure 9)
- k. Replace the chain cover.

2. Belt replacement (vulcanized endless belt and removable inside radius frame). Belt replacement is as follows:

- a. Remove the chain cover.
- b. Disconnect the drive unit by removing the gear reducer (shaft-mounted reducer) or removing the chain between the drive shaft and gear reducer (chain or belt driven units).
- c. Move the belt until the chain connecting link is on the top side of the conveyor.
- d. Loosen the chain tension by moving both end roll assemblies to their minimum adjustment positions.
- e. Remove the cross braces and return rolls.
- f. Separate the chain ends by removing the chain connecting link.
- g. Move the belt and chain until the end of the chain approaches the lower chain guide. Twist the belt slightly to allow the chain end to bypass the lower chain guide as you pull the belt under the conveyor. As the belt is pulled around, it will be released from the lower chain guide.
- h. Remove the inside radius frame.

Warning: Before the inside radius frame is removed, the end roll assemblies must be supported to avoid injury from the rolls falling and/or the slider bed and outside radius from tipping over.

- i. Remove the old belt and install the new belt.
- j. Install the inside radius frame.
- k. Insert the chain end into the lower chain guide and pull under the conveyor until the chain is within the lower guides and the chain end is on the top side of the conveyor.
- l. Join the two chain ends using a connecting link.

Note: The connecting link clip must be placed on the outer side of the chain with the open end facing away from the direction of travel. (See Figure 11)

- m. Readjust the belt and chain. (Refer to the Belt and Chain Figures 6 and 9.)
- n. Adjust the belt tension on the inside radius. (See Figure 9)
- o. Replace the return rolls and cross braces.
- p. Connect the drive unit by installing the gear reducer (shaft-mounted reducer), or reinstalling the drive chain or belt.
- q. Replace the chain cover.

3. Belt replacement (vulcanized endless belt on larger conveyors without removable inside radius frame). Belt replacement is as follows:

- a. Remove the chain cover.
- b. Disconnect the drive unit by removing the gear reducer (shaft-mounted reducer) or removing the chain between the drive shaft and gear reducer (chain or belt driven units).
- c. Move the belt until the chain connecting link is on the top side of the conveyor
- d. Loosen the chain tension by moving both end roll assemblies to their minimum adjustment positions.
- e. Remove the cross braces and return rolls.
- f. Separate the chain ends by removing the chain connecting link.
- g. Move the belt and chain until the end of the chain approaches the lower chain guide. Twist the belt slightly to allow the chain end to bypass the lower chain guide as you pull the belt under the conveyor. As the belt is pulled around, it will be released from the lower chain guide.

Note: If the conveyor has supports, they must be unbolted at the inside radius. The inside of the frame must be supported so that the belt can slip between the top of the supports and the bottom of the conveyor frame.

- h. Insert the chain end into the lower chain guide and pull under the conveyor until the chain is within the lower guides and the chain end is on the top side of the conveyor.
- i. Join the two chain ends using a connecting link.

Note: The connecting link clip must be placed on the outer side of the chain with the open end facing away from the direction of travel. (Refer to Figure 11)

- j. Readjust the belt and chain. (See Figures 6 and 9)
- k. Adjust the belt tension on the inside radius.
- l. Replace the return rolls and cross braces.

- m. Connect the drive unit by installing the gear reducer (shaft-mounted reducer), or reinstalling the drive chain or belt.
- n. Replace the chain cover.

I. Return Rolls

1. **Inspection:** During periodic inspections of the power turn, the return rollers should be checked to ensure that they are in good working condition. They should roll freely without any dents, gouges, or other damage. They should be clean without any foreign matter, such as adhesive tape stuck to the surface or wound around the shaft. The rubber covers on the rubber tire style rollers should be in good condition.
2. **Replacement:** If the return rolls are damaged or badly worn, they may be replaced as follows:
 - a. Remove the inside radius hanger bracket.
 - b. Remove the return roll shaft.
 - c. Replace the roll(s) on the shaft.
 - d. Reinstall the return roll shaft and attach the inside radius hanger bracket.

J. Lubrication: The upper and lower chain wear strips should be periodically lubricated. A mixture of dried grease and dust can greatly reduce the life of the chain and wear strips. This is especially true if the conveyor operates in dusty conditions. We recommend using Lubriplate Molith #2 grease. The frequency of lubrication and amount required will depend upon the load, speed, and environmental conditions. Some general guidelines are as follows: (See Figure 15)

Clean conditions @ 8 hours per day	Lube every 3-4 months
Clean conditions @ 18 hours per day	Lube every 6-8 weeks
Dusty conditions @ 8 hours per day	Lube every 4-6 weeks—Clean chain every 4-6 months
High humidity	Lube enough to stop rust and every 4-5 weeks

Warning: Running a conveyor that does not have adequate lubrication will damage the conveyor and substantially shorten the life of the chain.

- a. Periodic chain cleaning in solvent is highly recommended when operating in dusty conditions. After cleaning, apply new grease to the entire length of the chain and work it well into the moving parts.

Warning: Use proper safety precautions when handling solvents.

- b. All power turns have grease fittings in the chain cover. Some models also have grease fittings in the side of the frame on the outside perimeter. The number of grease fittings on your particular turn will depend upon size and arc. Each grease fitting is clearly marked.

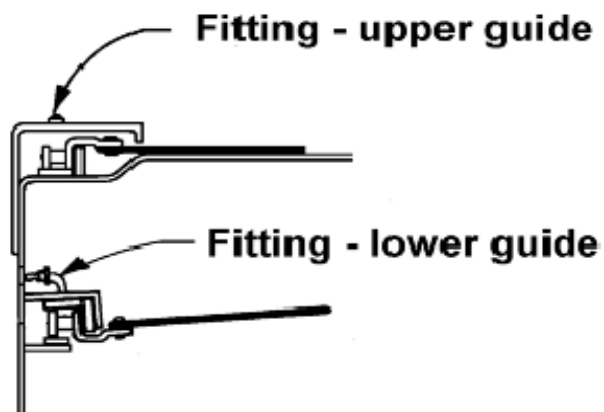

Figure 15

Note: If the conveyor is operating in a food application, refer to the appropriate government regulation for the correct type of food-grade grease.

K. Preventive Maintenance Schedule

Component	Service Interval	Maintenance Inspection
Complete Curve	First 40 hours	<ul style="list-style-type: none"> ✓ Visual check ✓ Chain tension ✓ Lubricate chain wear guides
Complete Curve	Monthly	<ul style="list-style-type: none"> ✓ Visual Check ✓ Ensure tightness of fasteners – especially the bolts on the side of the frame.
Conveyor Belt	Quarterly	<ul style="list-style-type: none"> ✓ Belt inspection ✓ Tension adjustment ✓ General condition and cleanliness ✓ Drive chain ✓ Lubricate as indicated in lubrication schedule ✓ Inspect attachment links ✓ Inspect seams
Drive Motor	Quarterly	<ul style="list-style-type: none"> ✓ Drive Motor inspection (visual) ✓ Ensure tightness of fasteners – especially the bolts on the side of the frame. ✓ Excessive noise ✓ Vibration

V. Drive Unit

A. Gear Reducer:

1. **Mounting bolts:** The mounting bolts should be inspected periodically to ensure that they remain tight and that no misalignment has occurred.
2. **Lubricant:** The gear reducer should be checked to ensure that the lubricant level is maintained at the manufacturer's recommended level. Consult the gear reducer manufacturer or their owner's manual before adding lubricant to confirm the correct lubricant to use. Some gear reducers are permanently sealed with an internal pressure compensation device. These gear reducers normally do not need the lubricant levels checked.
3. **Vent Plug:** Some gear reducers are shipped with a plastic plug in place of the vent plug. The plastic plug prevents oil from leaking during transportation. The plastic plug must be removed during the installation process and replaced with the correct vent plug. The vent plug is normally included with the package of fasteners or is fastened to the gear reducer; however, not all gear reducers are equipped with vent plugs.
4. **Temperature:** Temperature alone is not a good way to determine whether a gear reducer is going to fail. Some gear reducers are designed to operate for extended periods at elevated temperature levels that may seem excessive.

Note: Because temperature and noise levels can vary substantially between different brands or types of gear reducers, it is best to consult the gear reducer manufacturer or their owner's manual before performing maintenance on a gear reducer.

VI. Product Data Sheets

Form	Description
PD-7	Wear strip installation/instructions for wear strips (guides)
PD-9	C-face vertical mount, inside radius
PD-10	C-face underslung mounting
PD-11	V-belt mount, inside radius
PD-12	V-belt mount, outside radius
PD-15	C-face/chain drive mounting arrangement
PD-17	Improved inside radius return roll hanger mounting instructions
PD-21	C-face mount, inside radius
PD-22	C-face mount, outside radius
PD-24	Double reduction C-face mounting
PD-61	Tapered return rolls conversion to straight return roll
PD-84	V-Belt vertical drive mount, Inside Radius, flat turn
PD-85	V-Belt vertical drive mount, Outside Radius, flat turn
PD-93	Chain & sprocket vertical/side mount
PD-107	Belt Cutting and Lacing Instructions

VII. Troubleshooting Guide

Problem	Cause & Solution
<p>Belt lacing pulling out at the inside radius</p>	<ul style="list-style-type: none"> ▶ Belt tension on inside radius too tight Solution—Adjust inside radius end roll position ▶ Damaged belt from jam Solution—Replace belt assembly ▶ Excessively worn belt Solution—Replace belt assembly
<p>Grommets pulling out</p>	<ul style="list-style-type: none"> ▶ Belt tension inside radius too tight Solution—Adjust inside radius end roll position and tension ▶ Foreign object rubbing against belt Solution—Remove foreign object and repair grommet or replace belt
<p>Belt drive chain jumping the sprocket teeth</p>	<ul style="list-style-type: none"> ▶ Chain tension too loose Solution—Adjust chain tension (review Service and Maintenance section “C” [page 6] in this manual)
<p>Ticking noise near end of conveyor</p>	<ul style="list-style-type: none"> ▶ End roll sprocket out of position Solution—Adjust position of sprocket (review Service and Maintenance section “C” [page 6] in this manual) ▶ Worn sprocket Solution—Replace sprocket ▶ Worn chain wear guides Solution—Replace chain wear guides
<p>Loose end roll and end roll shaft</p>	<ul style="list-style-type: none"> ▶ Loose end roll bearing collars Solution—Adjust end roll position and lock bearing collars (review Service and Maintenance section “F” [page 13] in this manual) ▶ End roll bearing failure Solution—Replace end roll bearing ▶ Broken key in end roll keyway Solution—Replace key, end roll, and end roll shaft as required
<p>Squealing noise under the conveyor</p>	<ul style="list-style-type: none"> ▶ Frozen return roll bearing Solution—Replace return roll ▶ Foreign object stuck between return roll and belt Solution—Remove foreign object

VIII. Spare Parts

A. Recommended spare parts list for power turns

Listed below are the Spare Parts we recommend stocking for 1–5 Flomaster® Power Turns. By utilizing genuine Flomaster spare parts, you can be assured that these components are proper for your particular unit's continual operation and are backed by the full Flomaster warranty. When ordering, **please indicate the model and serial number** to ensure accuracy in parts replacement. Allow 2–3 weeks from receipt of order for shipment. We ship F.O.B. Cañon City, CO, U.S.A., net 30 days. **Note:** Model and serial numbers of unit are located on the inside radius frame of the turn; stamped into a metal identification plate.

Recommended Quantity	Portec Item Number	Description
1	2**	Replacement belt w/chain
20	4*	SP connecting links
10	5*	SP attachment links
10	6*	Rivet and washer set
10	7*	Nylon bushing
10	8*	Grommets
1	9*	End roll—drive
1	10	End roll sprocket
1	11	End roll Bearing—Outside Radius
1	12	End roll bearing—Inside Radius
1	13	End roll drive shaft (with extension)
1	14	Return roll assembly
1	27	Outside perimeter chain wear guide set
1	Tape	Maintenance video tape
*These parts are universal on all sizes.		
**Belts with laced seams will have lacing in both ends unless otherwise specified.		

For a complete recommended spare parts list with pricing for all Portec units within your facility, please contact our parts department at 719 275-7471.

IX. Parts List – Flomaster Power Turns

Always supply the following information when ordering or corresponding regarding replacement parts for your Flomaster Power Turn: **SERIAL NUMBER and MODEL NUMBER** from the name plate on the unit, and **REF. ITEM NUMBER** corresponding to your requirement from the Illustrated Parts Diagram. The Serial Number will ensure an equivalent replacement. To procure any parts not listed or shown, please consult Portec, Inc., Flomaster Division.

REF ITEM #	PART NAME AND DESCRIPTION	PORTEC PART #
1	Curved belt – Belt only supplied with grommets installed accompanied by necessary rivets, washers, and nylon bushings for attachment to customer's chain.	
2	Curved belt assembled with drive chain – Complete assembly, ready for replacement. Note: For turns with laced seams, standard replacement belts have lacing installed on both ends for easy belt replacement.	
3CT	Chain breaker tool – For breaking chain to replace special attachment link	190129
4	Special connecting link – A necessity in assembling turn drive chain. This is not a standard roller chain link, although the appearance is similar. Standard links will not permit proper tracking and may result in chain and belt damage.	Std. – 020238 Nickel Plated – 020235
5	Special attachment link – Connecting part between chain and belt. To replace broken attachment links, two special connecting links must be used with each attachment link.	Std. – 020229 Nickel Plated – 020230
6	Rivet and washer set – Attaches chain to belt	Std. – 600347 S/S – 600854
7	Nylon bushing – Use with rivet and washer assembly	080020
8	Grommet – Installed in belt	Std. – 190100 Nickel Plated – 190101
8CT	Installation punch and die tools for grommets	190121
9	End roll – Large tapered roll on each end of the conveyor. No bearings or shafts are included.	
10	End roll sprocket – Circular chain beveled-tooth sprocket	
11	End roll bearing; Outside Radius	
12	End roll bearing; Inside Radius	
13	End roll shaft; drive end – With drive shaft extension; includes keyways and keys.	

REF ITEM #	PART NAME AND DESCRIPTION	PORTEC PART #
14*	Return roll assembly – Includes shaft and roll(s)	
14a*	Single roll with bearings – Single return rolls are utilized instead of rubber tire style bearings on curves with rough top or white belt material.	
14b*	Return roll shaft only	
14c*	Rubber tire bearing – For return roll assemblies	
17**	Bed idler roll – Single with bearings	
19**	Bed idler roll shaft	
24	End roll shaft; non-drive – Without drive shaft extension; includes keyways and keys.	
25	Sideguard; Outside Radius	
26	Sideguard: Inside Radius	
27	Outside perimeter chain wear guides – Complete upper and lower set with installation hardware and instructions.	
28	Belt seam lacing – Belt lacing hooks with pin	
28a	Belt lacing pin	
28b	Vise lacing tool – For field installation of belt seam lacing	110007
29	Outside radius chain cover	
Tape	Maintenance Video Tape	192024
<p>*Located under the unit to support the belt on the return. **Not standard on all units.</p>		

X. Illustrated Parts Diagram

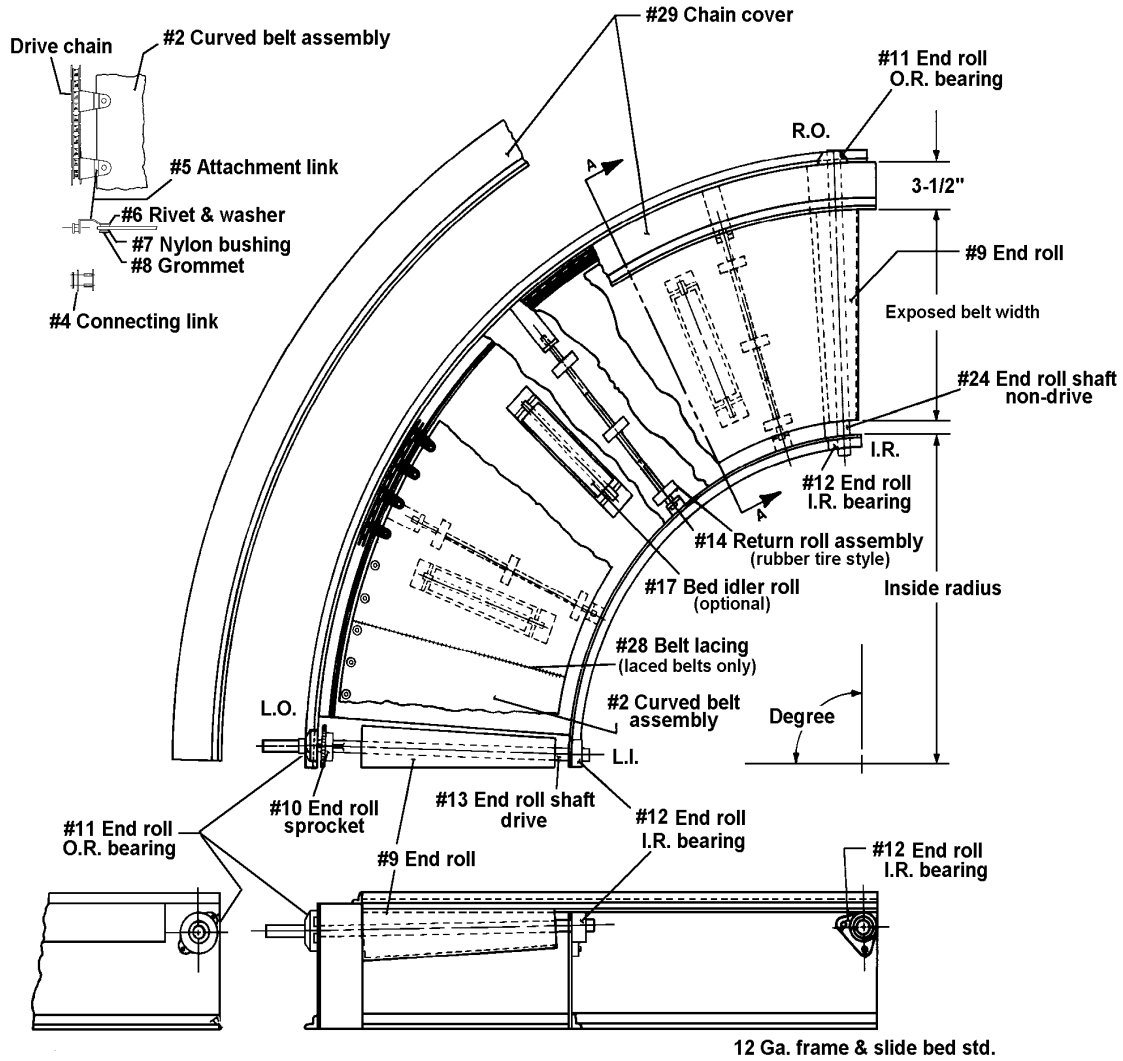

12 Ga. frame & slide bed std.

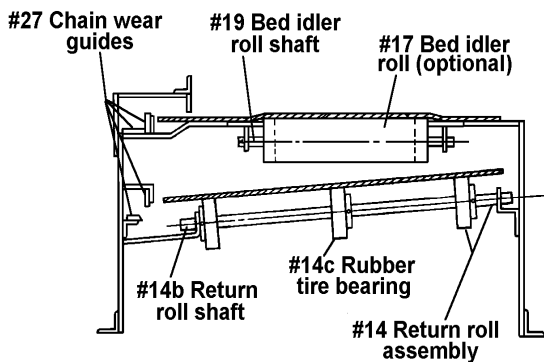

SECTION A-A
(with rubber tire style return roll)

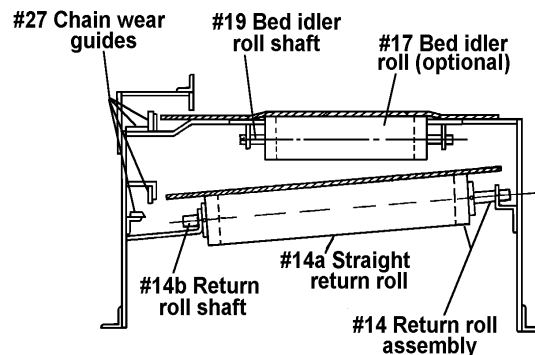

SECTION A-A
(with straight style return roll)

XI. Warranty

PORTEC INC., FLOMASTER DIVISION warrants the material and workmanship of its manufactured products, with exceptions noted below, for a period of 12 months beginning one month from the date of shipment from FLOMASTER DIVISION'S factory, according to recorded serial numbers.

Within the period noted above, any material or workmanship showing defects will be repaired or replaced, provided FLOMASTER DIVISION is given written notice within 30 days after failure, and a willingness is expressed to submit the product to FLOMASTER DIVISION, and if FLOMASTER DIVISION authorizes the return of the product, the product is returned. Warranty parts are supplied F.O.B. FLOMASTER DIVISION'S factory and unless express agreement is made by FLOMASTER DIVISION the purchaser shall bear expense of installation. FLOMASTER DIVISION reserves the right at any time to supervise or install any part of replacement, or supervise adjustment incident to satisfactory operation of equipment.

Unauthorized returns, modifications, additions or variations, from procedures and information contained in FLOMASTER DIVISION'S Owner's Manuals, and Product Data Bulletins, or any misuse, negligence, accident, product jam, or loading beyond rated capacity invalidates this warranty.

Exceptions:

1. Because of varying operating conditions, all belting supplied will necessarily be subject to manufacturer's warranty, rather than that of FLOMASTER DIVISION. *
2. In case of motor or reducer failure, please contact the nearest Authorized Representative of the manufacturer. This warranty is void if motor or reducer is tampered with or disassembled by other than the Authorized Representative. *
3. FLOMASTER DIVISION further reserves the right to void its warranty where final destination and specific application are withheld; product is improperly installed or maintained by others; product is improperly protected against hazards and adverse environmental conditions during storage prior to or during installation; and/or product is used for applications/conditions other than indicated upon placement of order.

*The FLOMASTER DIVISION will assist in the handling of warranty claims with such manufacturers to the end that satisfactory performance may be obtained.

THE FOREGOING WARRANTY IS EXCLUSIVE AND IN LIEU OF ALL OTHER WARRANTIES WHETHER WRITTEN, ORAL, OR IMPLIED (INCLUDING ANY WARRANTY OF MERCHANTABILITY OR FITNESS FOR ANY PURPOSE). UNDER NO CIRCUMSTANCES SHALL THE FLOMASTER DIVISION BE LIABLE FOR INCIDENTAL OR CONSEQUENTIAL DAMAGES.

The foregoing warranty cannot be changed except by written authorization signed by an authorized FLOMASTER DIVISION representative, and no attempt to repair or promise to repair or improve FLOMASTER DIVISION PRODUCTS by any other representative of the FLOMASTER DIVISION shall change or extend said warranty in any manner whatsoever.



Flomaster's Customer Service Department

WARRANTY + TM

Genuine Flomaster® Expanded Warranty Coverage for Your New Purchase of Flomaster Equipment

Let us help you prevent costly downtime!

For one low price—specified labor coverage during your standard first year parts warranty period plus specified labor coverage for one additional year, as well as discounts on replacement parts during the second year—will provide you peace of mind that your Flomaster equipment will be protected by genuine Flomaster maintenance and genuine Flomaster replacement parts.

- 10% parts discount for single purchase of the complete recommended spare parts list if purchased during the plan period.
- 5% parts discount on any parts purchased other than the complete spare parts list if purchased during the plan period.
- Two preventive maintenance visits (one per year) to provide inspection and limited service of the following as required:
 - Drive train alignment, condition, and performance
 - Reducer seals, oil level, and leaks
 - Bearings condition and lubrication
 - Drive mount/torque arm condition and adjustment
 - Drive guards clearance and condition
 - End roll assemblies condition, position, and performance
 - End roll guards condition and clearance
 - Belt and belt chain tension—adjust as required
 - Belt chain sprockets condition and position
 - Belt chain condition and lubrication
 - Chain guards condition and clearance
 - Belt attachments condition
 - Belt lacing condition
 - Belt condition
 - Upper and lower chain guides condition/lubrication
 - Return rolls/wheels condition and function
 - Provide service report at conclusion of preventive maintenance visit

Contact Customer Service today so a *WARRANTY + TM* can be arranged for your Flomaster equipment right away! Call (719) 275-7471



**Materials Handling Group
Flomaster® Division**

One Forge Road (Zipcode 81212)
P.O. Box 589
Cañon City, CO 81215-0589 USA

Tel.: 719 275-7471
FAX: 719 269-3750
portec@portec-mhg.com

Flomaster's Customer Service Department

INSTALLATION FIELD SERVICE

**Qualified Flomaster® Field Service Technicians
to Assist you in your Initial Installation**

Let us help you prevent costly downtime!

For one low price – Portec will provide you peace of mind that the installation of your Flomaster equipment to Flomaster's requirements is met and that your Flomaster equipment is adjusted properly for trouble free startup and top production performance.

Service may vary depending on the Customer's requirements, but can include such services as providing a qualified Field Service Technician to:

- Provide instruction, advisement, and limited assistance during assembly and/or installation of Flomaster equipment.
- Provide advisement and/or mechanical inspection of installed equipment.
- Perform final mechanical adjustments of equipment for proper alignment, belt tension, and drive alignment.
- Provide mechanical maintenance training for your crews.
- Provide assistance with interpretation of installation and operating instructions for accessory items for supplied Flomaster equipment.

Contact Customer Service today to arrange a "Tailor Made" installation field service for your mix and quantity of new equipment! Call 719 275-7471



Flomaster's Customer Service Department

MAINTENANCE AGREEMENTS

At Reasonable Prices

**Genuine Flomaster Field Maintenance Support
For Your New or Existing Flomaster Equipment**

Let us help you prevent costly downtime!

- **Two pre-scheduled preventive maintenance visits** to provide inspection and limited service of the following:
 - Drive train alignment, condition, and performance
 - Reducer seals, oil level, and leaks
 - Bearings condition and lubrication
 - Drive mount/torque arm condition and adjustment
 - Drive guards clearance and condition
 - End roll assemblies condition, position, and performance
 - End roll guards condition and clearance
 - Belt and belt chain tension—adjust as required
 - Belt chain sprockets condition and position
 - Belt chain condition and lubrication
 - Chain guards condition and clearance
 - Belt attachments condition
 - Belt lacing condition
 - Belt condition
 - Upper and lower chain guides condition/lubrication
 - Return rolls/wheels condition and function
 - Provide service report at conclusion of preventive maintenance visit
- 10% parts discount for single purchase of the complete recommended spare parts list if purchased during the plan period.
- 5% parts discount on any parts purchased other than the complete spare parts list if purchased during the plan period.
- 15% renewal discount. Portec, Flomaster will apply a 15% discount off of the list price of the service plan when the plan is renewed for consecutive periods.

Contact Customer Service today so a maintenance agreement can be “Tailor Made” for your mix and quantity of equipment! Call (719) 275-7471



PORTEC

Flomaster's Customer Service Department

CUSTOM MAINTENANCE TRAINING PROGRAMS

Genuine Flomaster Maintenance Training in Your Plant or at the Flomaster Factory

Let us help you prevent costly downtime!

Two full days of hands-on, step-by-step instruction in your plant or at the factory, that will provide your maintenance personnel with the knowledge to maintain your Portec Flomaster conveyors in top performing condition.

Scope of Training:

- Belt removal and change out
- Discussion of Maintenance/Owner's Manual and viewing of maintenance video
- Hands-on shop training to include:
 - Conveyor structure/fabrication
 - Structural erection and assembly sequence
 - Guides assembly/alignment
 - Slider bed alignment
 - End rolls sub-assemblies, assemble/disassemble and alignment
 - Sprockets/guides alignment
 - Wear strip installation
 - Belt repair: Belt joint preparation; lacing, grommets, chain attachment, chain, options
 - Drives: Arrangements, mountings, options, sprocket/pulley alignment
 - Lubrication: Drives, chain and guides
 - Belt and drive adjustment for correct alignment and top performance
 - Safety

Contact Customer Service today so a Custom Maintenance Training Program can be set up for your key personnel right away! Call (719) 275-7471

Notes