



*P.O. Box 589
Royal Gorge Industrial Park
Canon City, Colorado 81215-0589
Telephone: (719) 275-7471
Fax: (719) 269-3750
Telex: 450-0688*

KNIFE - EDGE®

Power Turn
OWNER'S MANUAL

MANUAL PS-84

MAINTENANCE AND INSPECTIONS SUGGESTIONS

Please refer to maintenance drawing on page 2 for location of parts described in the following instructions.

WARNING:

1. Be sure unit is not running and cannot be started while it is being serviced.
2. All guards must be in place at all times during operation.

Regular periodic inspection of the following components is essential to satisfactory operation of the Knife-Edge® Belt Power Turn.

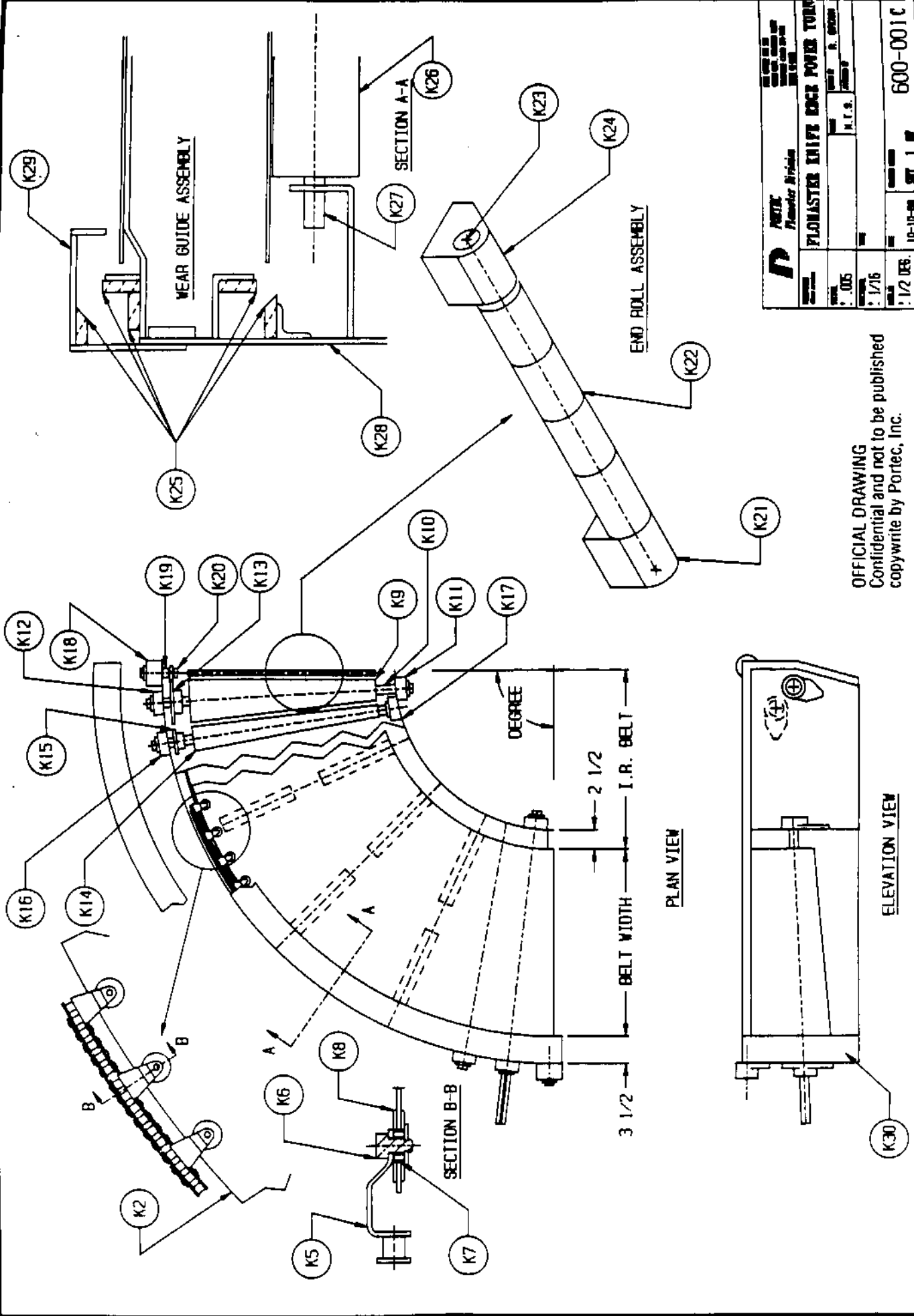

OFFICIAL DRAWING
Confidential and not to be published
copyright by Portec, Inc.

PLAN VIEW

ELEVATION VIEW

INDEX

SECTION	CONTENTS	PAGE
I.	Sprocket and Roll Alignment.....	4
II.	Chain Tension	7
III.	Belt Adjustment.....	8
IV.	Chain to Belt Attachments	9
V.	Belt Replacement	10
VI.	Wear Strip Replacement.....	13
VII.	Additional Tips for Maintenance.....	16
VIII.	Application Suggestions.....	18
IX.	Parts List.....	19
X.	Warranty.....	21

I. SPROCKET ROLL ALIGNMENT

- A. Remove bolts around perimeter of guard (Item K29) and lift off carefully - do not bend or distort.
- B. Check idler sprockets (Item K20) on each end of turn:
Refer to Fig. 1 and 3.
 1. Sprocket must be aligned in the center of normal chain path. Align idler sprocket (Item K20) with center of chain by loosening bearing (Item K18), locking collar and sliding shaft (Item K19) in or out to line up sprocket.
 2. If idler sprocket is set too high or too far in toward belt, it will cause a wrinkle to form in belt as it crosses over the end rolls (Item K22). This adjustment has been made at the factory and permanently set. It should not require adjustment.
 3. Check set screws for presence and tightness.

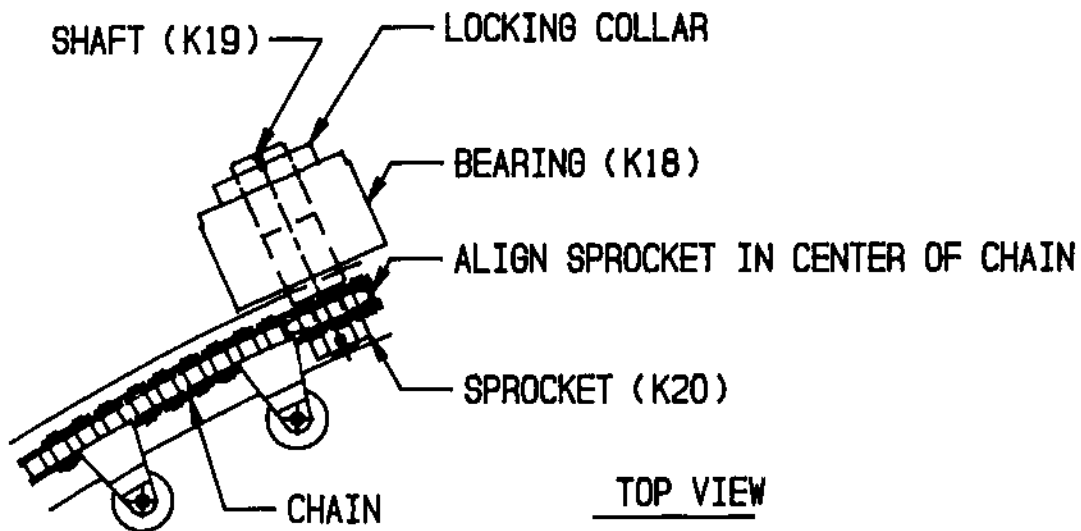
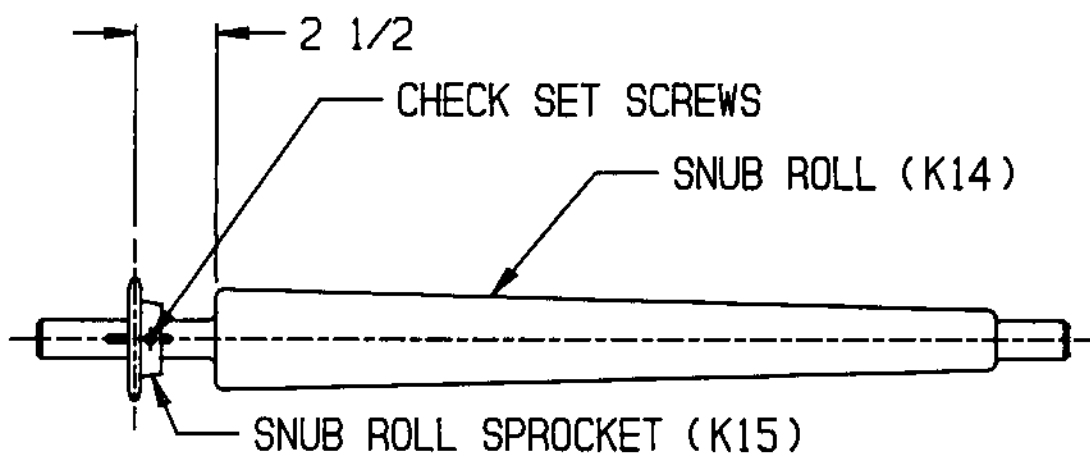

FIG. 1

- C. Snub roll and sprocket alignment (refer to Fig. 2) is achieved by moving snub roll shaft horizontally in or out of supporting bearings, thereby moving sprocket (Item K15) so chain will feed on to and off of lower chain guide smoothly. Do **NOT** attempt to change position of sprocket by moving it along shaft changing dimension shown.



SNUB ROLL & SPROCKET ALIGNMENT
FIG.2

- D. Drive and non-drive roll alignment (refer to Fig. 3) is achieved by adjusting roll assemblies so chain will guide on to and off of sprocket (Item K13) as smoothly as possible. This is a horizontal movement of the shaft in or out of the supporting bearings (K11, K12). Do **NOT** attempt to change position of sprocket by moving it along shaft changing dimension shown.

Locate rolls such that they conform to contour of the belt - vertical movement.

If wrinkles occur between drive or non-drive rolls and end rolls (Item K22), they are usually caused by sprocket (Item K13) being too far toward inside radius of turn. Adjust roll assembly so rivets (Item K6) are floating freely as they go around sprocket.

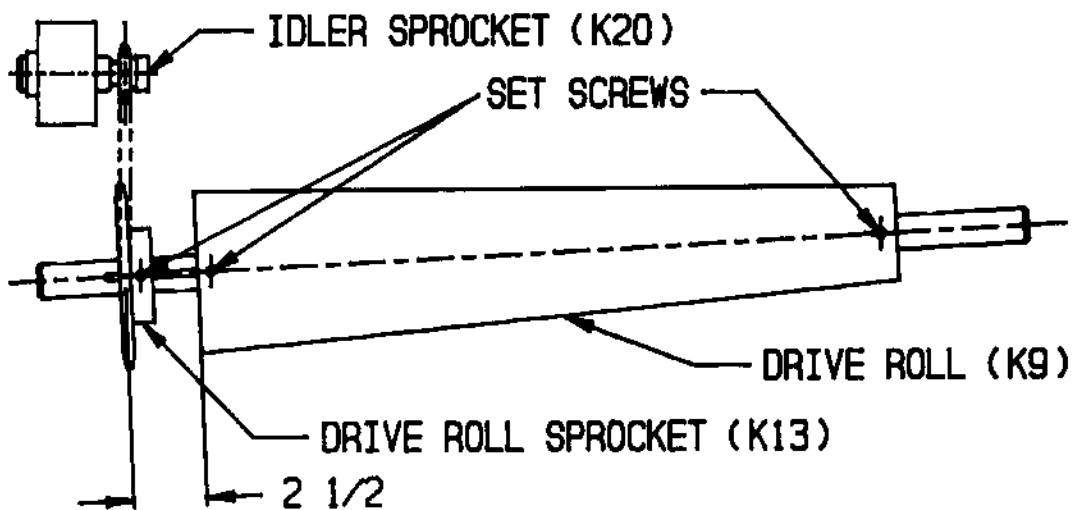

IDLER SPROCKET & DRIVE SPROCKET ALIGNMENT

FIG. 3

- E. The following information relates to set screws in sprockets and tapered rolls.

All Flomaster® Turns equipped with steel sprockets are shipped from factory equipped with set screws as follows:

1. A Nylock socket set screw with cupped point will be used at all keyway locations on end pulleys and sprockets.
2. A Nylock set screw with half dog point will be used on all set screws not positioned over keyways.

It is extremely important these different types of set screws not be interchanged as to location because of the specific locking function each type accomplishes. This assembly will assure no thrust slippage of rolls or sprockets.

II. CHAIN TENSION

- A. The Knife-Edge® Belt Power Turn is a light-duty turn with a maximum loading of 15 lbs per linear foot of belt length and a maximum belt speed of 100 feet per minute. As with the Flomaster Power Turn, the Knife-Edge® is a chain driven belt conveyor and does not require tension in the belt to transmit power. The belt follows the chain. Because of the light loads experienced with this turn, chain elongation does not occur to any extent requiring continued tensioning of chain.

However, it is advisable to check tension periodically. Chain tension must be snug-but not too tight. It should be snug enough to prevent chain from jumping sprocket teeth while under load. Overtightening can result in excessive heat build-up in chain wear strips (Item K25) and cause damage to idler sprocket shaft (Item K19).

- B. Tensioning chain is accomplished by loosening the outside bearing (Item K12) supporting the drive and /or non-drive rolls one at a time (Item K9) and moving them accordingly. Refer to Fig. 4. Check drive and /or non-drive roll sprockets (Item K13) alignment with chain (paragraph I-D) before final tightening of bearing bolts. Do not attempt to tension chain by adjusting idler sprockets at ends of turn.

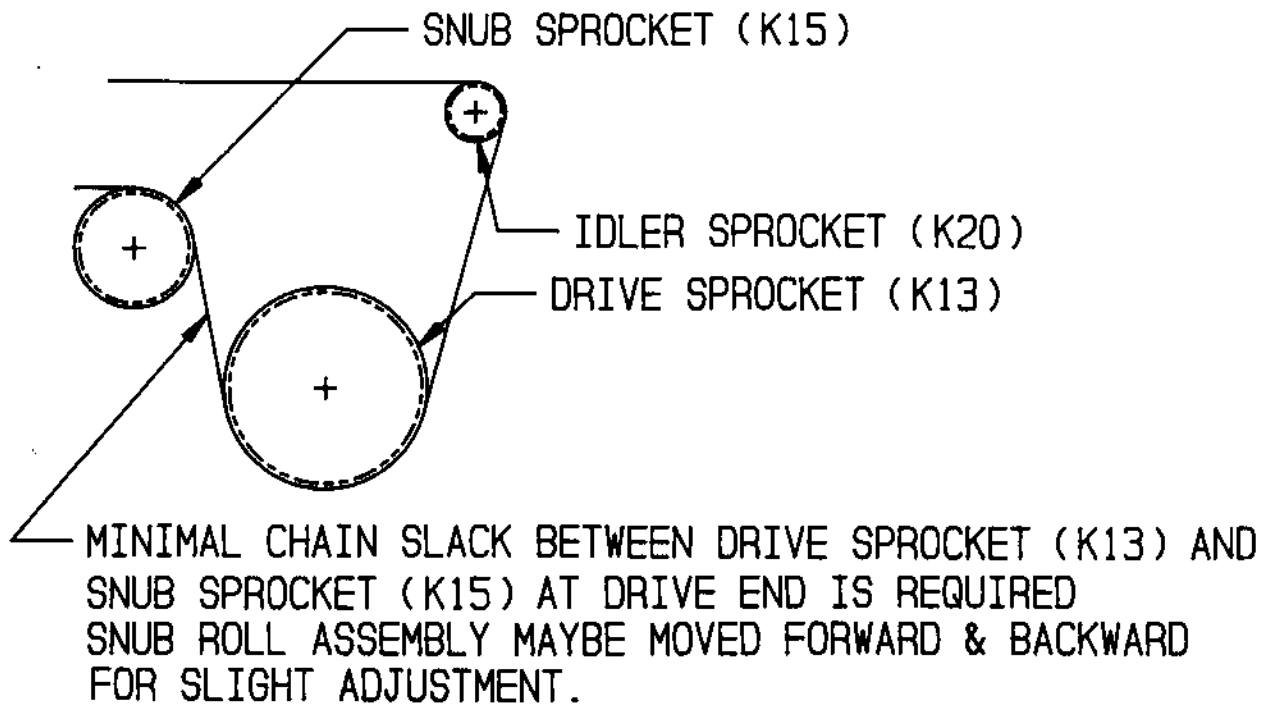

CHAIN TENSION

FIG. 4

III. BELT ADJUSTMENT

- A. Proper belt adjustment is achieved by having equal belt tension across the belt surface between the end rolls (Item K22) and drive and non-drive rolls (Item K9). Excessive belt tension will result in overheating at the end rolls. This can be observed by distinct end roller and mounting block impression patterns being very visible through the belt. Belt being too loose will result in belt not achieving "Knife-Edge" pattern or conforming to end roll surface.
- B. Once chain tension has been initially established, it is necessary to make adjustments at inside radius of drive and non-drive rolls and snub rolls. Also, because of the compound angles involved, lateral adjustment of drive/non-drive rolls to re-align sprockets may be necessary. Refer to Fig. 3.

IV. CHAIN TO BELT ATTACHMENT LINKS (ITEM K5)

- A. Periodic check should be made to ascertain whether any of these links are broken and if so, broken pieces should be removed immediately from belt to prevent damage to belt and turn. Link should then be replaced as soon as practical with new part. Fig. 5.
- B. When breakage is found, the cause should be ascertained if possible and immediate action taken. The most common causes are:
1. Incorrect belt tensioning on inside radius.
 2. Change in belt due to excessive humidity, moisture, or chemical reaction causing shrinkage.
 3. Foreign object getting under guard.
 4. Overload caused by obstruction on conveyer.
- C. Undue breakage should be reported to Flomaster Division.

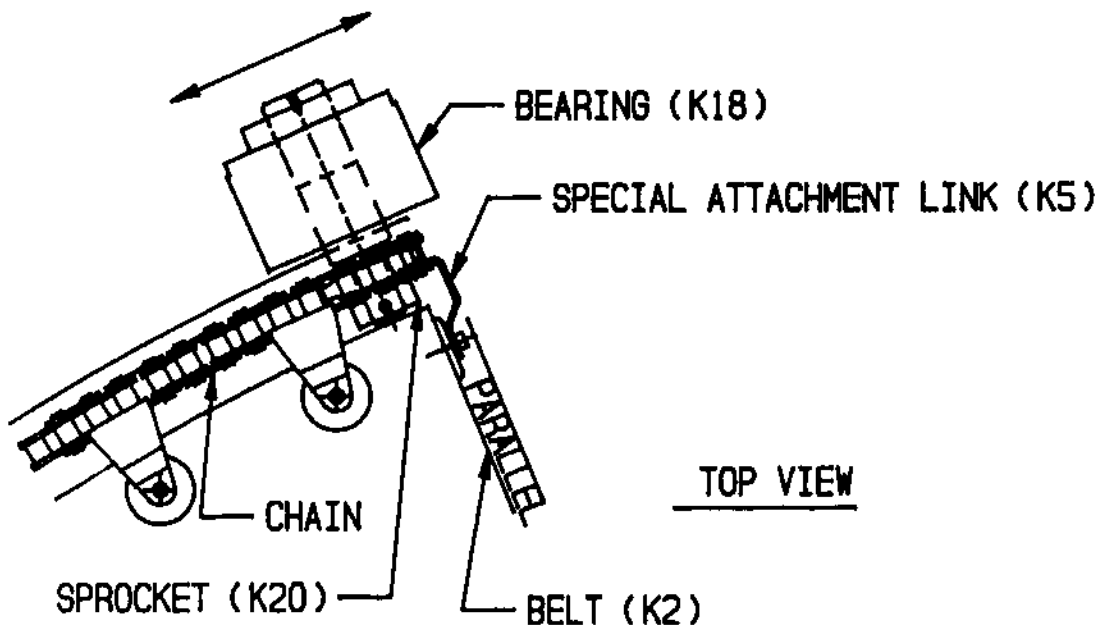

SPECIAL ATTACHMENT LINKS AND BELT SHOULD BE PARALLEL.
TO ADJUST MOVE BEARING (K18) HORIZONTAL.

FIG. 5

V. BELTING REPLACEMENT

- A. Certain steps are recommended in replacement of Flomaster® Knife-Edge® belts which are outlined below. Please refer to previous paragraphs for adjustments, etc.
- B. Before proceeding to the following steps, there are several items to consider and note.
 - 1. Mark positions of all bearings on outside and inside frames before loosening or removing.
 - 2. It is recommended for units with drives located on inside radius that drives and drive supports be removed.
 - 3. Any floor supports or supports hung from above must be removed from inside radius to install belt.
 - 4. It is recommended that set screws on outside radius bearings of drive or non-drive rolls **NOT** be loosened and rolls removed. If rolls are moved then critical sprocket position and alignment is lost and must be re-positioned later during final adjustments.
 - 5. The customer has the option regarding the removal of the old belt. It can be removed by cutting the belt or it can be removed as a unit, noting that once the belt is cut, it is unserviceable.
 - 6. Once the old belt has been removed it is recommended that the old roll bushings (Item K22) be inspected. Look for bushings not turning freely. Remove and clean as required. Note any bushings cracked or broken then replace if necessary. Lubricate as determined with Dow No. 7 compound.
 - 7. Turns of 180° have fixed inside radius frame. Turns smaller than 180° have removable (bolted) inside radius frames.

VULCANIZED ENDLESS BELT INSTALLATION

180 Degree Curves:

1. Remove chain cover (K29)
2. Disengage drive from drive shaft and remove if on inside radius.
3. Move belt around turn until chain connecting link (Item K4) is found and positioned near drive end on top of turn.
4. Loosen belt tension by raising both drive and non-drive (K19) rolls at inside and outside radius.
5. Remove return rolls (K26) and lower frame cross braces.
6. Remove snub roll assemblies (K14).
7. At this point old belt can be cut to remove or it can be removed in one piece as follows:
 - a. Separate chain at connecting link and feed chain through lower guide such that open end of trailing chain can be routed to outside of lower guide. Continue to pull chain toward tail end of turn until chain is free of lower guide.
 - b. Lay portion of belt on top of conveyor over to inside radius of frame.
 - c. Separate any conveyor supports from inside radius frame and pull belt out from between supports and frame.
8. With chain connecting link removed from new belt, insert belt between supports and slip over frame such that open ended chain is located at one end of the lower chain guide.
9. Take note as chain is fed into lower guide that top surface of belt will ultimately be to outside when completely threaded onto conveyor. Feed chain through entire length of lower guide with additional chain pulled out such that connecting link will be on top near center of turn.
10. With chain ends near center of slider bed, attach with connecting link clip toward the outside radius and then slip chain over user guide.
11. Replace frame cross braces and return rolls.
12. Replace snub rolls taking note of previous bearing positions.
13. Adjust belt and chain according to previous sections of this manual and lubricate chain.
14. Replace chain cover.
15. Install drive as required.

CURVES WITH REMOVABLE (BOLTED) INSIDE RADIUS FRAME

1. Remove chain cover (K29).
2. Disengage drive from drive shaft and remove if on inside radius.
3. Move belt around turn until chain connecting link (Item K4) is found and positioned near drive end on top of belt.
4. Loosen belt tension by raising both drive and non-drive (K19) rolls at outside radius, then remove inside radius bearings from frame. Leave outside bearings secured to shafts.
5. Remove return rolls (K26) and lower frame cross braces.
6. Remove snub roll assemblies (K14).
7. Unbolt inside frame and remove (will be necessary to block up conveyor on inside.)
8. At this point old belt can be cut to remove or it can be removed in one piece as follows:
 - a. Separate chain at connecting link and feed chain through lower guides such that open end of trailing chain can be routed to outside of lower guide. Continue to pull chain toward tail end of turn until chain is free of lower guide.
 - b. Separate any supports from inside radius frame and slip belt off of turn.
9. With connecting link removed, slip new belt over slider bed into position such that open end chain is located at one end of the lower chain guide.
10. Replace inside radius frame.
11. Feed chain through entire length of lower guide so master link position is on slider bed placing chain in position of upper guide and connect connecting link.
12. Replace frame cross braces and return rolls.
13. Replace inside radius bearings.
14. Replace snub rolls taking note of previous bearing positions.
15. Adjust belt and chain according to previous sections of this manual and lubricate chain.
16. Replace chain cover.
17. Install drive as required.

VI. INSTALLATION INSTRUCTIONS FOR WEAR STRIPS (GUIDES)

- A. Remove chain cover and chain (per previous sections).
 Take note of belt and assembly spacing between lower guide strips
 as noted on the drawing, Fig. 6.

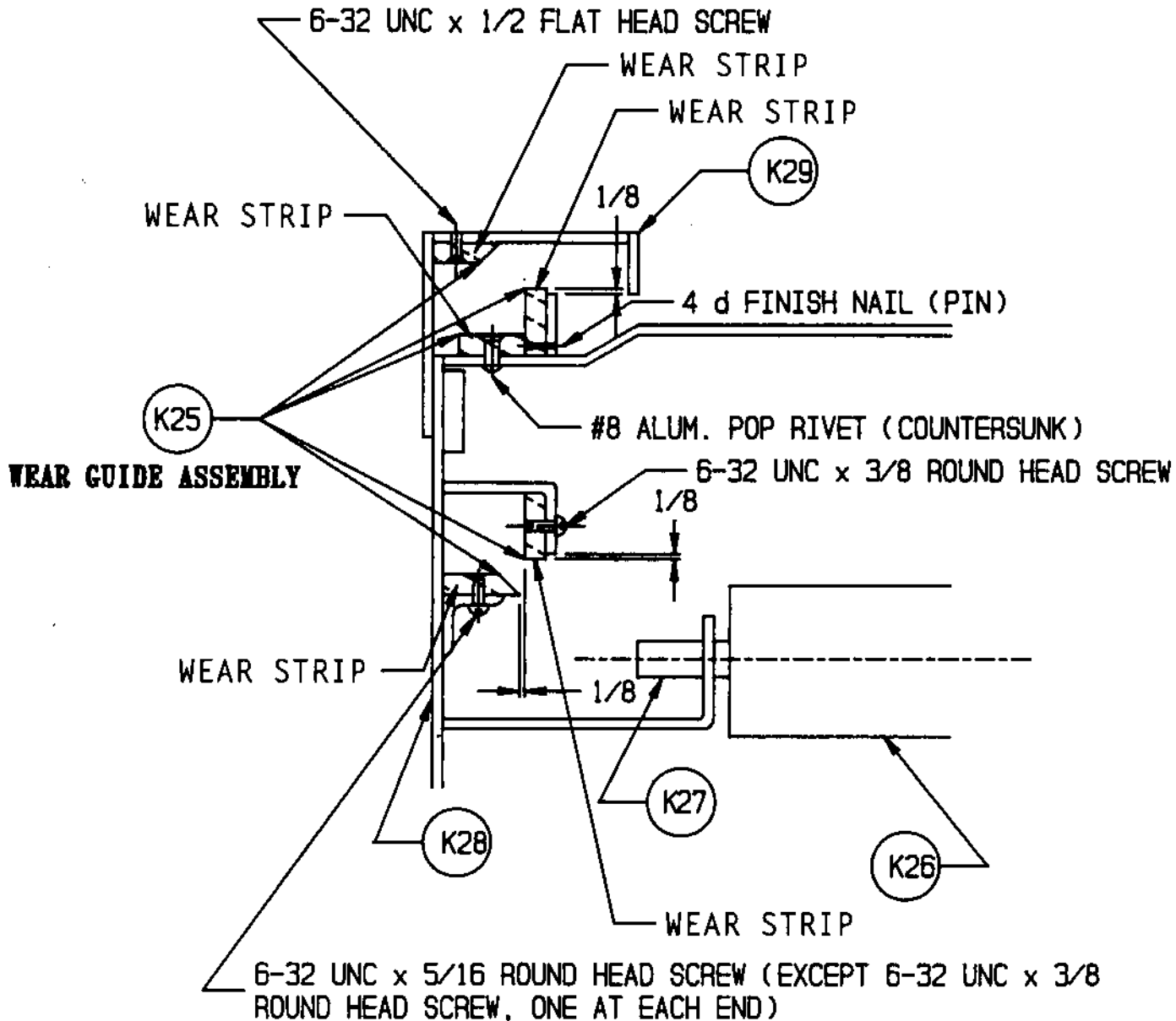
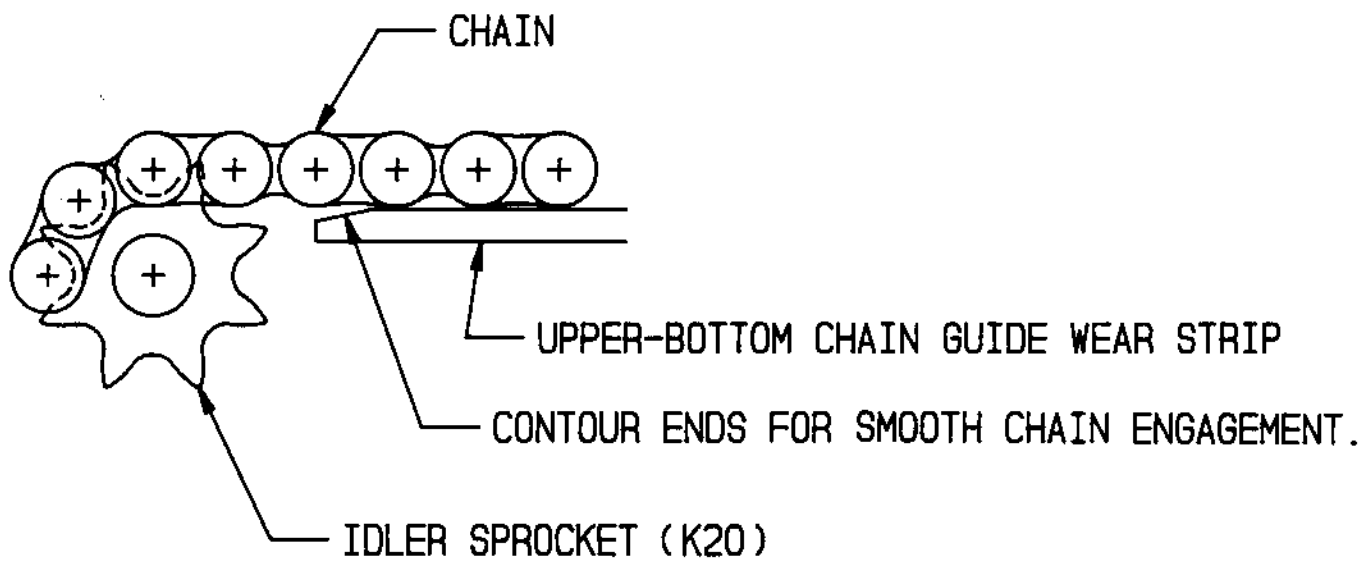

FIG. 6

- B. Remove old guides, noting positions.
- C. The lower guides with the 45 degree edge must be installed as shown using self tapping screws provided (pilot hole must be drilled).
- D. The other lower guide piece must be spaced as shown and attached with self tapping screws provided.
- E. The top guide on the chain cover can be replaced by counter sinking the hole to accept the flat head screw. (Do **NOT** allow screw head to protrude from guide material.)
 - 1. The vertical guide on top is sitting on the bed surface and held in place with 4d finish nails acting as pins. Head should be flush with material and pin snipped off if it extends beyond metal backing piece, after the horizontal strip is installed.
 - 2. The horizontal piece is positioned against the vertical piece and attached with 1/8" (3.18mm) pop rivet, counter sunk to eliminate a protruding rivet head. This piece covers and holds pins and vertical wearstrip in place.
- F. Contour ends similar to the original pieces for quiet chain engagement. Refer to Fig. 7.
- G. Feed belt and chain through guides.
- H. Re-lube and tighten chain per previous sections.
- I. Replace chain cover.



CHAIN SHOULD FEED ON TO AND OFF OF IDLER SPROCKET (K20) PARALLEL TO CHAIN GUIDE WEAR STRIP. TO ADJUST MOVE BEARING (K18) VERTICALLY UNTIL CHAIN IS POSITIONED PROPERLY.

FIG. 7

VII. ADDITIONAL TIPS FOR BEST FLOMASTER® MAINTENANCE

- A. All Flomaster® Power Turns are equipped with Alemite Grease Fittings located near the end of the chain guard on the outer perimeter of the turn. The lubricant recommended for use with these fittings is Lubriplate Molith #2. Frequency of lubrication and amount of lubricant would in all instances depend upon the type of service of each individual power turn according to the judgement of those persons charged with maintenance. A general guide for conditions could be as follows (also see note on page 17):
1. Eight hour per day operation in comparatively clean surroundings, sufficient lubricant to grease chain each 3 to 4 months.
 2. Eighteen hour per day operation under clean conditions, each 6 weeks to 2 months.
 3. Eight hour per day operation, in excessively dusty or dirty conditions, each month or 6 weeks, with chain being cleaned with fuel oil each 4 to 6 months.
 4. In high humidity conditions chain should be lubricated sufficiently often to permit no rust formation and to assure no admittance of moisture into the roller chain. A monthly shot of grease would not be too often.
- B. Neither weld nor apply excessive heat on any portion of power turn frame.
- C. Do not drill holes for guard attachment or other reasons before ascertaining exactly whether a critical part may be affected.
- D. As on all belt conveying equipment, protection for the belt from excessive moisture or extreme humidity changes cannot be stressed too greatly.

The recommended lubricant is MOLITH #2 or equal. This is a "Lubriplate" product. The amount to use is "plenty" — make sure the chain is thoroughly coated to excess by visual inspection.

VIII. APPLICATION SUGGESTIONS

- A. Certain chemicals and oils can decrease belt life significantly. If you feel you have a potential problem, consult the factory.
- B. Repeated hard starts will have a tendency to reduce belt and drive component life on the Knife-Edge® Power Turn. Due to this shock action, a soft-start device is recommended to allow the drive mechanism to be softened.
 - 1. The potentiometer should be set as soft as possible yet still give satisfactory drive results.
 - 2. Set the potentiometer low and increase gradually to desirable setting.
 - 3. Do not set higher than is necessary to obtain desired performance.
- C. **VARIABLE SPEED DRIVES:**
Drive speeds which cause motor to operate at 50% or less of their design speed (usually 1750 rpm) for extended periods of time may cause motor to overheat because of slow fan speed and improper cooling.

Additionally, it is recommended a clutch be used, when stop/starts exceed 8 per minute, to allow motor to run continuously and cool properly.

The chain and belt, among other parts in Flomaster® Power Turns, are specially built for our company by selected manufacturers. They are expensive to replace and our aim is to keep wear, tear, and replacement for you at a minimum. We offer our cooperation and invite your questions and suggestions that we may better serve you and produce a better product. The equipment has been thoroughly shop tested before shipment; however, under conditions of shipment and operating conditions, we ask that operation be observed carefully for a short period with possible adjustments made in accordance with these instructions.
PLEASE GIVE SERIAL NUMBER WHEN WRITING CONCERNING OR ORDERING PARTS FOR YOUR FLOMASTER® TURN.

CHAIN DRIVEN KNIFE-EDGE TURN

Item No.	Part Name and Description	Reference Drawing 600-001
*K1	Curved Belt - Belt only, supplied with grommets installed, and vulcanized endless; accompanied by necessary rivets and washer, and nylon bushings for attachment to customer's chain.	
K2.	Curved Belt assembled with drive chain-complete, ready to install belt assembly.	
*K3.	Drive Chain - Chain only, for replacement; comes with rivet, washers, nylon bushings, and connecting link for attachment to customer's belt.	
*K3ct.	Chain Breaker Tool.	
*K4.	Special Connecting Link - a necessity in assembling turn drive chain. This is not a standard roller chain link although the appearance is similar. Standard links will not permit proper tracking and may result in chain and belt damage.	
K5.	Special Attachment Link - connecting part between chain and belt. To replace a broken link, two special connecting links (item 4) must be used.	
K6.	Rivet and Washer - for attaching chain to belt.	
K7.	Nylon Bushing - use with rivet and washer assembly.	
K8.	Grommet - installed in belt.	
*K8ct.	Grommet installation punch and die.	
K9.	Drive and Non-Drive Roll - formed tapered roll with hubs.	
K10.	Drive and Non-Drive Roll Shaft - drive shaft has extension to apply power source.	
K11.	Drive and Non-Drive Roll I.R. Bearing with Safety Cap.	

- K12. Drive and Non-Drive O.R. Bearing with Safety Cap.
- K13. Drive and Non-Drive Roll Sprocket.
- K14. Snub Roll - machined tapered roll with shaft.
- K15. Snub Roll Sprocket.
- K16. Snub Roll O.R. Bearing with Safety Cap.
- K17. Snub Roll I.R. Bearing.
- K18. Idler Sprocket Bearing with Safety Cap.
- K19. Idler Sprocket Shaft.
- K20. Idler Sprocket.
- K21. End Roll End Cap - Right hand and left hand required.
- K22. End Rolls - 1" long; 5/8" O.D. X 3/8" I.D. Nylatron.
- K23. End Roll Shaft - 3/8" Diameter case-hardened shaft.
- K24. End Roll Center Support.
- K25. Outside Perimeter Wear Guides - upper and lower set.
- K26. Return Roll - 1.90" O.D. with 7/16" hex bore.
- K27. Return Roll Shaft 7/16" hex shafting.
- K28. Frame Assembly.
- K29. Chain Cover Top Assembly.
- K30. Chain Cover End Cap.
- * These items not shown.



TERMS AND CONDITIONS

VALIDITY – Quotations shall be considered current if outstanding no more than thirty (30) days from date of quotation, unless otherwise stated on quotation.

FREIGHT POLICY – Shipments of products, unless otherwise stated, is EX WORKS PORTEC'S factory. Written claims for damage in shipment should be made against the carrier. Written claims for shortages should be made against the carrier, specifically if there is evidence of shipping carton/container damage and/or if according to the shipping records there is a discrepancy in numbers of containers shipped versus numbers received.

Only in a situation where the container(s) shipped have been received in good condition, checked for physical content, and signed for verification within three days of delivery, and if such shortage has been found, and if PORTEC is notified in writing within 10 days upon receipt of order, PORTEC will establish that there was or was not a shortage. If a shortage is determined, PORTEC will provide the customer with the product/parts at PORTEC'S expense and shall ship F.O.B. as stated in the freight policy. If no shortage is determined, or if others than PORTEC caused the shortage, the claim shall be deemed invalid and it shall be the responsibility of the customer to arrange payment to PORTEC to fill the requirements of the deficiency.

PRICE ACCEPTANCE – The prices quoted herein are based on the quantities specified. Any change in quantities may affect quoted price. All orders are subject to acceptance at PORTEC'S factory. Any expense incurred by PORTEC as a result of cancellation or the making of any change will be included in PORTEC'S invoice unless prior waiver of such expense is obtained from PORTEC.

SHIPMENTS – Quoted Shipment dates are subject to change, without liability for delays beyond PORTEC'S control.

TERMS OF PAYMENT – Invoices are payable net cash 30 days, unless otherwise noted. There will be an interest charge of 1-1/2% per month for all payments received after 35 days. International (**except Canada**) orders are shipped against confirmed irrevocable letters of credit. All payments shall be in U.S. dollars. If the financial responsibility of a purchaser becomes impaired or is unsatisfactory, or if credit is not established, PORTEC reserves the right to request payment in advance or satisfactory guarantee that invoices will be paid promptly when due.

QUALITY ASSURANCE – All of its manufactured products are subject to PORTEC'S Warranty for material and workmanship.

GENERAL – Terms, conditions, and product specifications are subject to change without further obligation to PORTEC.

LIMITED WARRANTY ON NEW EQUIPMENT – PORTEC provides a Limited Warranty that warrants the material and workmanship of its manufactured products, with exceptions noted, for a period for 60 months beginning one month from the date of shipment from PORTEC'S factory, according to recorded serial numbers.

Within the stated warranty period, any material or workmanship showing defects will be repaired or replaced, provided PORTEC is given written notice within 30 days after failure, and a willingness is expressed to submit the product to PORTEC, and

if PORTEC authorizes the return of the product, and the product is returned. This warranty does not cover against normal wear of parts or materials. Warranty parts are supplied via EX WORKS PORTEC'S factory and unless PORTEC makes express agreement, the purchaser shall bear the expense of installation. PORTEC reserves the right at any time to supervise or install any part of replacement, or supervise adjustment incident to satisfactory operation of equipment. *A possible Warranty PO for parts and/or service may be required prior to shipping parts or exercising warranty labor.*

ITEMS IDENTIFIED AS COMPONENT AND REPLACEMENT PARTS – PORTEC parts will be warranted for a period of one (1) year from the date of shipment from the PORTEC Factory. This warranty on parts will cover only defects in workmanship or material. *The warranty does not cover the costs of the installation of such parts unless authorized by the designated PORTEC representative.*

Unauthorized returns, modifications, additions or variations, from procedures and information contained in PORTEC'S Owner's Manuals, and Product Data bulletins, or any misuse, negligence, accident, product jam, or loading beyond rated capacity invalidates this warranty.

EXCEPTIONS:

1. Because of varying operating conditions, all belting supplied will necessarily be subject to manufacturers', warranty rather than that of PORTEC.

2. Some OEM equipment including motors and gear reducers will be subject to the manufacturer's warranty, not PORTEC'S. PORTEC Customer & Product Support will provide assistance in contacting the proper manufacturer's representative. If a replacement is provided from PORTEC stock, a Possible Warranty PO must be provided. If the warranty is deemed invalid and PORTEC is not reimbursed for the warranty claim, the PO will be exercised.

3. PORTEC further reserves the right to void its warranty where final destination and specific application are withheld; product is improperly installed or maintained by others; product is modified without the consent from the designated PORTEC service representative; product is improperly protected against hazards and adverse environmental conditions during storage prior to or during installation; and/or product is used for applications/conditions other than indicated upon placement of order.

The foregoing warranty is exclusive and in lieu of all other warranties whether written, oral, or implied (including any warranty of merchantability or fitness for any purpose). Under no circumstances shall PORTEC be liable for incidental or consequential damages. The foregoing warranty cannot be changed except by written authorization signed by an authorized PORTEC representative, and no attempt to repair or promise to repair or improve PORTEC products by any other representative of PORTEC shall change or extend said warranty in any manner whatsoever.