



Portec, Inc .
One Forge Road (81212)
PO Box 589
Cañon City, CO 81215-0589 USA
Tel.: +1-719 275-7471
Fax: +1-719 269-3750
Email: sales@portec.com
Website: www.portec.com

END-ROLL

STRAIGHT

Straight Belt Conveyor

OWNER'S MANUAL

Conveyor Location: _____

Model Number: _____

Serial Number: _____

Year of Manufacture: _____

TABLE OF CONTENTS

	Page
Section I. Conveyor Safety Precautions	3
Section II. Tool Requirements for Conveyor Installation, Maintenance, & Belt Replacement	5
Section III. Preventive Maintenance	6
• Inspection & Service Schedule	7
Section IV. Belt Adjustments	8
Section V. Belt Replacement Procedure	9
Section VI. Illustrated Parts Diagram	10
Section VII. Spare Parts List	11
Section VIII. Terms and Conditions	12

Section I

CONVEYOR SAFETY PRECAUTIONS

Portec Flomaster does not install conveyors, therefore, it is the responsibility of the contractor, installer, owner and user to install, maintain and operate the conveyor, components and conveyor assemblies in such a manner as to comply with all national, state and local laws and ordinances, including the Occupational Safety and Health Act, and the American National Standards Institute (ANSI) B20.1 Safety Code and Z244 Lockout/Tagout.

In order to avoid an unsafe or hazardous condition, the conveyors or parts must be installed and operated in accordance with the following minimum provisions.

1. Conveyors shall not be operated unless all covers and/or guards for the conveyor and drive unit are in place. If the conveyor is to be opened for inspection cleaning, maintenance or observation, the electric power to the motor driving the conveyor must be LOCKED OUT/TAGGED OUT in such a manner that the conveyor cannot be restarted by anyone; however remote from the area, until conveyor cover or guards and drive guards have been properly replaced.
2. If the conveyor must have an open housing as a condition of its use and application, the entire conveyor is then to be guarded by a railing or fence in accordance with the current revision ANSI standard B20.1.
3. Do not attempt any maintenance or repairs of the conveyor until power has been LOCKED OUT/TAGGED OUT.
4. Always operate conveyor in accordance with these instructions and those contained on the caution labels affixed to the equipment.
5. Do not place hands, feet, or any part of your body, in the conveyor.
6. Never walk on conveyor covers or guards. Never climb, sit, stand, or work from a conveyor.
7. Do not use conveyor for any purpose other than that for which it was intended.
8. Do not poke or prod material into the conveyor with a bar or stick inserted through the openings.
9. Keep the area around conveyor drive and control station free of debris and obstacles.
10. Eliminate all sources of stored energy (materials or devices that could cause conveyor components to move without power applied) before opening the conveyor
11. Do not attempt to clear a jammed conveyor until power has been LOCKED OUT/TAGGED OUT.
12. Do not attempt field modification of conveyor or components without prior approval of Portec Flomaster.
13. Conveyors are not normally manufactured or designed to handle materials that are hazardous to personnel. These hazardous materials include those that are explosive, flammable, toxic or otherwise dangerous to personnel. Conveyors may be designed to handle these materials. If hazardous materials are to be conveyed, Portec Flomaster should be consulted prior to any modifications.
14. When two or more conveyors are interfaced or joined together, make sure there is adequate guarding, pinch point protection and safety devices.
15. Only trained operators should be permitted to operate and maintain conveyors. Training needs to include instruction in operation under normal conditions and emergency conditions.
16. All starting and stopping devices should be clearly marked and the immediate area kept clear of obstructions to permit ready access.
17. The areas around loading and unloading points should be kept clear of any obstructions.

18. A person should NOT PERMITTED TO RIDE on any conveyor not specifically designed and approved to convey people.
19. Workers working around or operating conveyors should be shown the location of the starting and stopping devices and instructed how to use them to stop the conveyor in an emergency.
20. Do not use a conveyor for any purpose other than that for which it was intended. A conveyor should only be used to transport material it is capable of handling safely.
21. Under no circumstances should safety guarding or labels attached to the conveyor be altered or removed without written permission from the owner/manufacturer. If the labels attached to the equipment become illegible, order replacement warning labels from Portec Flomaster or Conveyor Equipment Manufacturer's Association (CEMA) at www.cemanet.org.
22. Routine inspections and Preventive and Corrective maintenance programs should be conducted to ensure that all safety features and devices are in place and functioning properly.
23. Employees should be alerted to the potential hazard of entanglement in conveyors caused by items such as long hair, loose clothing, and jewelry.
24. As a general rule, conveyors should not be cleaned while in operation. Where proper cleaning requires the conveyor to be in motion and a hazard exists, personnel should be made aware of all associated hazards as indicted above and take proper precautions.
25. If the conveyor is equipped with pneumatic systems, LOCK-OUT/TAG OUT the air supply before attempting any maintenance, such as changing filters.

Additional Safety Notes:

Disconnecting and locking out the power to the motor driving the unit provides the only real protection against injury. Secondary safety devices are available; however, the decision as to their need and the type required must be made by the owner-assembler as Portec Flomaster has no information regarding plant wiring, plant environment, the interlocking of the conveyor with other equipment, extent of plant automation, etc. Other devices should not be used as a substitute for locking out the power prior to removing guards or covers. We caution that use of the secondary devices may cause employees to develop a false sense of security and fail to lock out power before removing covers or guards. This could result in a serious injury should the secondary device fail or malfunction.

Electrical controls, machinery guards, railings, walkways, arrangement of installation, training of personnel, etc., are necessary ingredients for a safe working place. It is the responsibility of the contractor, installer, owner and user to supplement the materials and services provided by Portec Flomaster to make the conveyor installation comply with the law and accepted standards.

Examples of Safety Labels used on conveyors:



Section II

Tool Requirements for Conveyor Installation, Maintenance, and Belt Replacement

Tool	Used For
15 mm or 7/8" Wrench	Take-up Roll Tensioners
15 mm or 9/16" Wrench or Socket	Bearing Housing to Frame 1-3/16" (30 mm) dia shaft & smaller
18 mm or 3/4" Wrench or Socket	Bearing Housing to Frame 1-7/16" (35 mm) dia shaft & larger
Socket Wrench Set with 3/8" drive and imperial and/or metric sockets	Standard Drive Arrangements Slider Bed Removal
5/32" Allen Wrench	End Rolls
5/32" Allen Wrench	Bearing to Shaft 1-7/16" (35 mm) dia. shaft & larger
1/8" Allen Wrench	Bearing to Shaft 1-3/16" (30 mm) dia. shaft & smaller
3/32" Allen Wrench	Return Wheels
Electricians Nut Driver Set Or Adjustable Wrench	Electrical Motor Connections

NOTE: Only trained personnel should perform all required work on the conveyor to prevent any danger to operators or other persons, and to prevent damage to the conveyor.

WARNING: Disconnect and lock-out power before performing any installation or maintenance procedures. All guards must be in place before startup of conveyor.

Section III Preventive Maintenance

Perform a complete conveyor inspection after the first 40 hours of operation.

- Check belt tracking and tension.
- Check drive components for alignment and check that all fasteners are secure.

A Portec conveyor may be provided with regreaseable bearings at the drive roll. Lubricate at the same time as other system conveyors, which are typically on a quarterly service interval. A lithium based grease of a NLGI #2 consistency is recommended for most situations.

NOTE: No other lubrication is required on the conveyor.

Maintain the lubrication of the gearbox and drive chain (if equipped) according to the manufacturer's recommendations.

Keep the area between the conveyor belt and bedplate relatively free from debris. Excessive debris may cause premature belt wear.

WARNING: Always disconnect the power and perform the appropriate lock-out/tag-out procedures before beginning service or maintenance on the conveyor.

Inspection & Service Schedule

Component(s)	Service Interval	Task(s)	Comments
Conveyor	Monthly	Check belt tracking.	Adjust position if required.
		Check belt tension.	To tighten belt, adjust the position of the take-up roll.
		Check belt condition.	Observe overall condition for fraying, cuts, gouges, seams, etc.
		Check drive components alignment/performance.	Adjust if required.
		Check that all fasteners and hardware are secure.	Tighten if required. Do not operate unless secure.
		Check that all guards are securely in place and properly adjusted.	Readjust for clearances and secure.
Belt	Quarterly	Check for belt and seam damage.	Repair or replace as needed.
End Roll	Quarterly	Check end roll bearings for noise and lubrication.	Lubricate or replace as needed.
		Check end roll alignment.	Adjust if required.
		Check drive roll assembly location and ensure that the set screws are tight.	Adjust/tighten if required.
		Check shafts for condition with no visible damage.	If shaft is damaged from spinning in loose bearing collar or sprocket, replace as needed.
Drive Arrangement	Quarterly	Check drive sprockets/chain or v-belts for wear.	Replace as needed.
		Check motor/reducer or gear motor for noise.	Adjust if required or replace as needed.
		Check chain or belt tension.	Adjust if required.
		Check gear box lubrication level.	Refer to manufacturer's specifications.
Return Rollers	Semi-Annually	Check return rollers for noise.	Replace as needed.
		Check to ensure that return rollers are in contact with belt.	Adjust if required.
		Check that return rollers turn freely when in contact with belt.	Replace as needed.

Section IV Belt Adjustments

End Roll Adjustment

The purpose of the adjustable end rolls (ER-6) is to lengthen or shorten the conveyor as required for proper product transfer. Total normal adjustment is 1" (25 mm). The end roll assembly must be perpendicular to the conveyor side frame.

Note: The End Roll should not be used to adjust belt tension.

Belt Tension Adjustment

The belt tension is adjusted with the take-up roll bearing unit (ER-14). Belt tension should be enough to make the belt conform to the crown of the end rollers.

Note: Do not attempt to remove cupping on the edge of the belt by increasing belt tension.

Belt Tracking Adjustment:

Belt tracking is normally controlled by adjustments to the Take-up Roll (ER-12). On some long conveyors, the Return Rolls ER-9) may also be used to control tracking.

1. Set the End-Roll (ER-6) so that it is perpendicular to the conveyor side frames and parallel to the conveyor bed surface.
2. Set the Take-up Roll (ER-12) perpendicular to the conveyor side frame and set the belt tension.
3. Adjust one side of the Take-up Roll until the belt is centered in the conveying path. If the belt runs to one side of the conveying path, increase the belt tension slightly on that side of the conveyor belt to bring the belt into the center of the conveying path. The End-Roll (ER-6) may only be used to make fine adjustments to the belt tracking. After making a small adjustment to the Take-up Roll or End Roll, wait until the adjustment has had its full affect on the belt before making further adjustments. It is very easy to over-adjust.

Section V

Belt Replacement Procedure

Removing the Conveyor Belt – Vulcanized Endless Belt

1. Isolate the electrical supply.
2. Separate the drive unit from the drive roll. If the conveyor uses a V-belt, chain or timing belt to drive the drive roll, simply remove the belt or chain from the drive shaft. If the conveyor has a shaft-mounted gear reducer, it will be necessary to move the gear reducer from the drive shaft.
3. Remove the Take-up Roll (ER-12) and Return Rolls (ER-9).
4. Remove the Frame Cross Braces (ER-16).
5. Remove the floor support mounting bolts on one side of the conveyor frame
6. Lift up the conveyor slightly and slide the conveyor belt off the side of the conveyor.

Removing the Conveyor Belt – Laced Belt

1. Isolate the electrical supply.
2. Separate the drive unit from the drive roll. If the conveyor uses a V-belt, chain or timing belt to drive the drive roll, simply remove the belt or chain from the drive shaft. If the conveyor has a shaft-mounted gear reducer, it will be necessary to move the gear reducer from the drive shaft.
3. Loosen the Take-up Roll (ER-12) by loosening the Take-up Roll Adjustment Bolt (ER-15).
4. Remove the lacing pin from the belt seam lacing and remove the old belt.

Installing the Conveyor Belt:

Installing a conveyor belt is done in the opposite sequence of removing the belt. After installing the conveyor belt, adjust the belt for tension and tracking.

Note: Before installing the belt, check all parts for wear and/or damage. Replace any parts as necessary.

Section VI
Illustrated Parts Diagram — End-Roll Straight

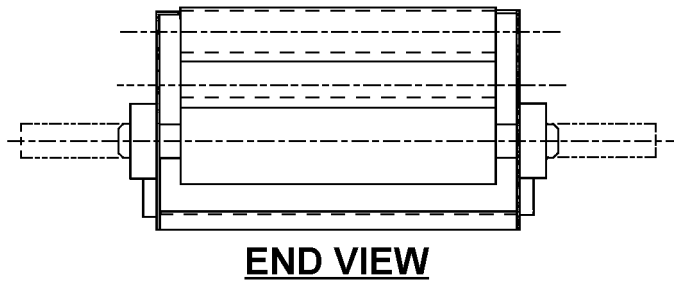
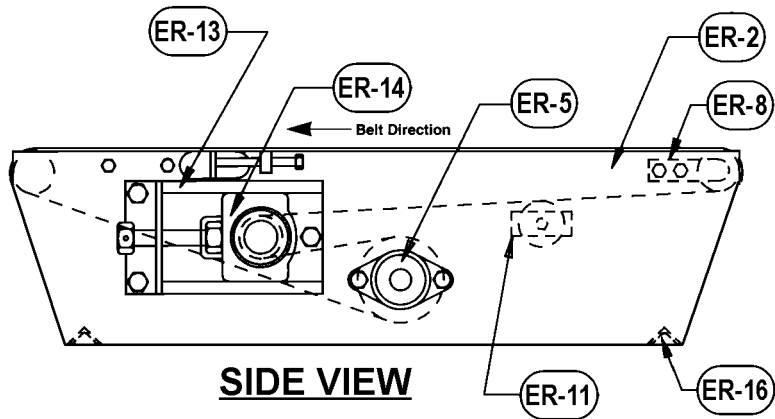
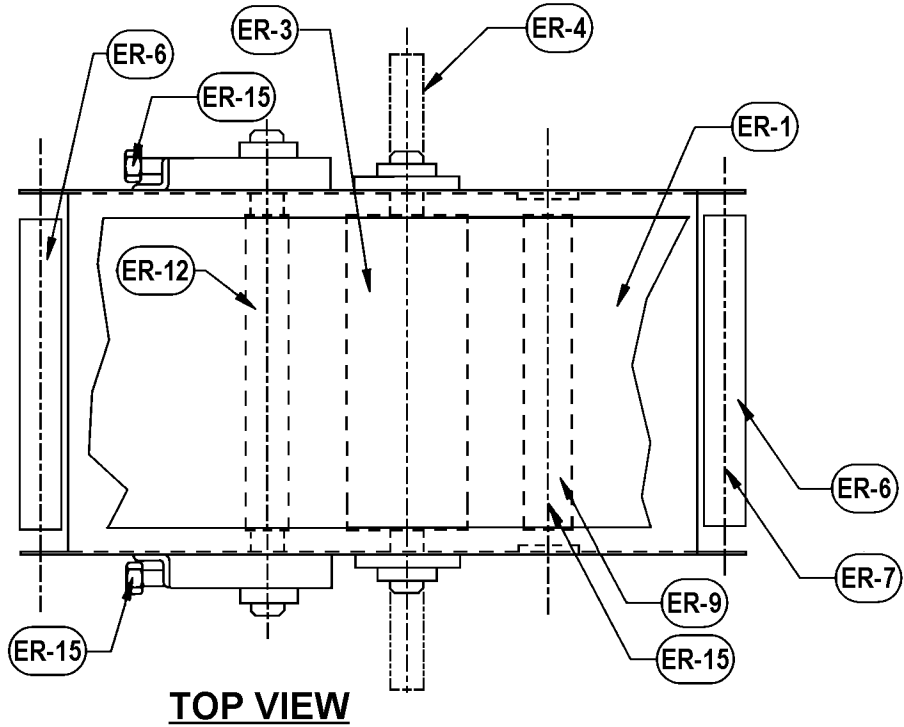

Section VII

END-ROLL STRAIGHT – SPARE PARTS LIST

Please supply the following information when ordering or corresponding with us regarding replacement parts for your Portec End-Roll Straight: **SERIAL NUMBER and MODEL NUMBER from the name plate on the conveyor, and PORTEC ITEM NUMBER corresponding to your requirement from the illustrated Parts Diagram.** The Serial Number (or the specific part number, if known) will ensure an equivalent replacement. To obtain any part not listed or shown, please consult our Parts Department at +1(719) 275-7471 extensions 220 or 253.

ITEM	PART DESCRIPTION	PORTEC PART NO.
ER-1	CONVEYOR BELT – VULCANIZED ENDLESS OR LACED	
ER-3	DRIVE ROLL (LAGGED)	
ER-4	DRIVE ROLL SHAFT	
ER-5	DRIVE ROLL BEARINGS	
ER-6	END ROLL ASSEMBLY WITH SHAFT AND ROLLERS	
ER-7	END ROLL SHAFT	
ER-8	END ROLL HANGER	
ER-9	RETURN ROLL WITH BEARINGS	
ER-10	RETURN ROLL SHAFT (7/16" HEX)	
ER-11	RETURN ROLL MOUNTING BLOCK	
ER-12	TAKE-UP ROLL	
ER-13	TAKEUP ROLL BEARING FRAME	
ER-14	TAKE-UP BEARINGS	
ER-15	TAKE-UP ROLL ADJUSTMENT BOLT	
ER-16	FRAME CROSS BRACES	



TERMS AND CONDITIONS

VALIDITY – Quotations shall be considered current if outstanding no more than thirty (30) days from date of quotation, unless otherwise stated on quotation.

FREIGHT POLICY – Shipments of products, unless otherwise stated, is EX WORKS PORTEC'S factory. Written claims for damage in shipment should be made against the carrier. Written claims for shortages should be made against the carrier, specifically if there is evidence of shipping carton/container damage and/or if according to the shipping records there is a discrepancy in numbers of containers shipped versus numbers received.

Only in a situation where the container(s) shipped have been received in good condition, checked for physical content, and signed for verification within three days of delivery, and if such shortage has been found, and if PORTEC is notified in writing within 10 days upon receipt of order, PORTEC will establish that there was or was not a shortage. If a shortage is determined, PORTEC will provide the customer with the product/parts at PORTEC'S expense and shall ship F.O.B. as stated in the freight policy. If no shortage is determined, or if others than PORTEC caused the shortage, the claim shall be deemed invalid and it shall be the responsibility of the customer to arrange payment to PORTEC to fill the requirements of the deficiency.

PRICE ACCEPTANCE – The prices quoted herein are based on the quantities specified. Any change in quantities may affect quoted price. All orders are subject to acceptance at PORTEC'S factory. Any expense incurred by PORTEC as a result of cancellation or the making of any change will be included in PORTEC'S invoice unless prior waiver of such expense is obtained from PORTEC.

SHIPMENTS – Quoted Shipment dates are subject to change, without liability for delays beyond PORTEC'S control.

TERMS OF PAYMENT – Invoices are payable net cash 30 days, unless otherwise noted. There will be an interest charge of 1-1/2% per month for all payments received after 35 days. International (**except Canada**) orders are shipped against confirmed irrevocable letters of credit. All payments shall be in U.S. dollars. If the financial responsibility of a purchaser becomes impaired or is unsatisfactory, or if credit is not established, PORTEC reserves the right to request payment in advance or satisfactory guarantee that invoices will be paid promptly when due.

QUALITY ASSURANCE – All of its manufactured products are subject to PORTEC'S Warranty for material and workmanship.

GENERAL – Terms, conditions, and product specifications are subject to change without further obligation to PORTEC.

LIMITED WARRANTY ON NEW EQUIPMENT – PORTEC provides a Limited Warranty that warrants the material and workmanship of its manufactured products, with exceptions noted, for a period for 60 months beginning one month from the date of shipment from PORTEC'S factory, according to recorded serial numbers.

Within the stated warranty period, any material or workmanship showing defects will be repaired or replaced, provided PORTEC is given written notice within 30 days after failure, and a willingness is expressed to submit the product to PORTEC, and

if PORTEC authorizes the return of the product, and the product is returned. This warranty does not cover against normal wear of parts or materials. Warranty parts are supplied via EX WORKS PORTEC'S factory and unless PORTEC makes express agreement, the purchaser shall bear the expense of installation. PORTEC reserves the right at any time to supervise or install any part of replacement, or supervise adjustment incident to satisfactory operation of equipment. *A possible Warranty PO for parts and/or service may be required prior to shipping parts or exercising warranty labor.*

ITEMS IDENTIFIED AS COMPONENT AND REPLACEMENT PARTS – PORTEC parts will be warranted for a period of one (1) year from the date of shipment from the PORTEC Factory. This warranty on parts will cover only defects in workmanship or material. *The warranty does not cover the costs of the installation of such parts unless authorized by the designated PORTEC representative.*

Unauthorized returns, modifications, additions or variations, from procedures and information contained in PORTEC'S Owner's Manuals, and Product Data bulletins, or any misuse, negligence, accident, product jam, or loading beyond rated capacity invalidates this warranty.

EXCEPTIONS:

1. Because of varying operating conditions, all belting supplied will necessarily be subject to manufacturers', warranty rather than that of PORTEC.

2. Some OEM equipment including motors and gear reducers will be subject to the manufacturer's warranty, not PORTEC'S. PORTEC Customer & Product Support will provide assistance in contacting the proper manufacturer's representative. If a replacement is provided from PORTEC stock, a Possible Warranty PO must be provided. If the warranty is deemed invalid and PORTEC is not reimbursed for the warranty claim, the PO will be exercised.

3. PORTEC further reserves the right to void its warranty where final destination and specific application are withheld; product is improperly installed or maintained by others; product is modified without the consent from the designated PORTEC service representative; product is improperly protected against hazards and adverse environmental conditions during storage prior to or during installation; and/or product is used for applications/conditions other than indicated upon placement of order.

The foregoing warranty is exclusive and in lieu of all other warranties whether written, oral, or implied (including any warranty of merchantability or fitness for any purpose). Under no circumstances shall PORTEC be liable for incidental or consequential damages. The foregoing warranty cannot be changed except by written authorization signed by an authorized PORTEC representative, and no attempt to repair or promise to repair or improve PORTEC products by any other representative of PORTEC shall change or extend said warranty in any manner whatsoever.