

## **CONTINUOUS • VERTICAL • UNIT • HANDLING**

**The answer to your  
vertical conveying needs...**



### ***Spiral-Lift Applications***

- ***Airport Baggage Handling***
- ***Distribution Centers***
- ***Factories***
- ***Printing Plants***
- ***Food Processing Facilities***
- ***Beverage Plants***

### ***Convey It Up or Down***

- Saves floor space
- Requires no metering, accumulation or indexing
- Positive drive belt system means no end roll slip
- Wide selection of entry and exit combinations
- Custom designed for your particular operation
- Durable all steel construction
- Fully assembled or modular construction
- High conveying speeds available
- Steep angles of incline/decline available (over 30° @ centerline)
- Wide belt widths available
- Over 40 years experience building spiral belt conveyors

# SPIRAL-LIFT®

## Standard Models



### Spiral Belt Conveyor

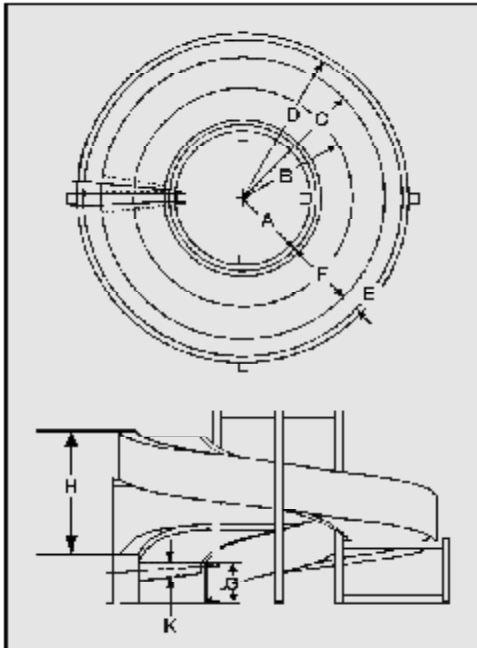

### Entry/Exit Orientation

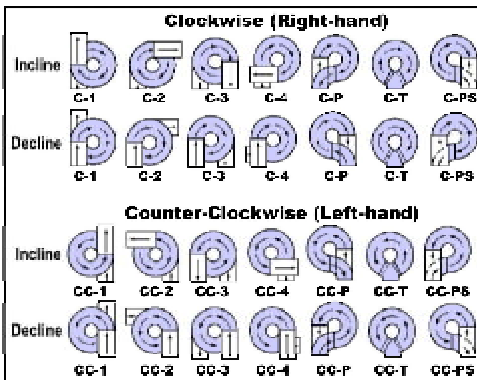

Note: Conveyors in white are not provided by Portec.

MODEL NUMBERS **	CONSTANT DIMENSIONS	Inside Radius A	Conveying Centerline B	Conveying Width F	End Roll Dia.* K	Gear-In 1 rpm F mm	Maximum Elevation per 360° H
<b>"LT" Spiral Family (127-381 conveying width; standard 25 mm shaft Ø)</b>							
573LM127SP	C-700 D=789 Frame Ht=178	573	636.5	127	80.3	225	1220
522LM178SP		522	611	178	77.5	216	1220
319LM381SP		319	509.5	381	66.1	180.1	1220
<b>"LN" Spiral Family (178-483 conveying width; standard 25 mm shaft Ø)</b>							
772LM178SP	C-950 D=1039 Frame Height=178	772	861	178	81.7	229.3	1524
620LM330SP		620	785	330	75.3	209	1524
467LM483SP		467	708.5	483	68.8	188.7	1524
<b>"A" Spiral Family (178-635 conveying width; standard 25 mm shaft Ø)</b>							
1022M178SP	C-1200 D=1289 Frame Height=216	1022	1111	178	128.7	376.9	2642
717M483SP		717	958.5	483	112.2	325.2	2642
565M635SP		565	882.5	635	104	299.4	2032
<b>"B" Spiral Family (178-940 conveying width; standard 30 mm shaft Ø)</b>							
1322M178SP	C-1500 D=1589 Frame Height=216	1322	1411	178	131.9	386.8	3251
1017M483SP		1017	1258.5	483	118.6	345	3251
814M686SP		814	1157	686	109.7	317.2	2642
560M940SP		560	1030	940	98.6	282.4	2032
<b>"C" Spiral Family (178-1000 conveying width; standard 35 mm shaft Ø)</b>							
2022M178SP	C-2200 D=2289 Frame Height=216	2022	2111	178	136	399.7	5080
1616M584SP		1616	1908	584	123.7	360.9	5080
1362M638SP		1362	1781	838	116.1	337.3	4674
1200M1000SP		1200	1700	1000	111.2	321.9	4166
<b>"HC" Spiral Family (1001-1245 conveying width; standard 35 mm shaft Ø)</b>							
1160HM1040SP	C-2200 D=2289 Frame Height=305	1160	1680	1040	158.8	471.3	3658
1110HM1090SP		1110	1655	1090	156.5	464.3	3658
955HM1245SP		955	1577.5	1245	149.6	442.6	3658

\* End roll diameter at conveying centerline including belt thickness of 6.35 mm.

Note: Conveying width (F) is equivalent to the "between sideguard" (BSG) width. The exposed belt width is approximately 25 mm narrower than the nominal conveying width (F). The outside radius frame, chain cover and both sideguards extend 9.5 mm past the true angle at both ends of the conveyor. The inside radius frame length matches the true angle.

For more information, contact:

#### HEADQUARTERS & FACTORY:

**PORTEC FLOMASTER**  
One Forge Road (81212)  
PO Box 589  
Cañon City, CO 81215-0589 USA  
Tel: +1(719) 275-7471  
Fax: +1(719) 269-3750  
Web: [www.portec.com](http://www.portec.com)  
Email: [sales@portec.com](mailto:sales@portec.com)

#### U.K. SALES OFFICE:

**PORTEC INTERNATIONAL LTD.**  
Tel: +44(0) 116 224 3698  
Fax: +44(0) 116 224 3698  
Email: [jimhempstock@portecgroup.fsnet.co.uk](mailto:jimhempstock@portecgroup.fsnet.co.uk)

#### GERMAN SALES OFFICE:

Tel: +49(0) 5193 972 1249  
Fax: +49(0) 5193 972 1248  
Email: [volker@portec.com](mailto:volker@portec.com)

### Standard Models

The above list is only a small example of the model sizes available from Portec. There are 6 standard family sizes of Spiral-Lift based upon the outside conveying radius (C) and a range of conveying widths (F). Any conveying width with the available range and having one of the 5 standard outside conveying radii, is considered a standard model. While Portec frequently designs and builds special radius Spiral-Lifts, the standard models represent the best value and shortest production lead-time.