

KNIFE-EDGE®

Small Product Transfer

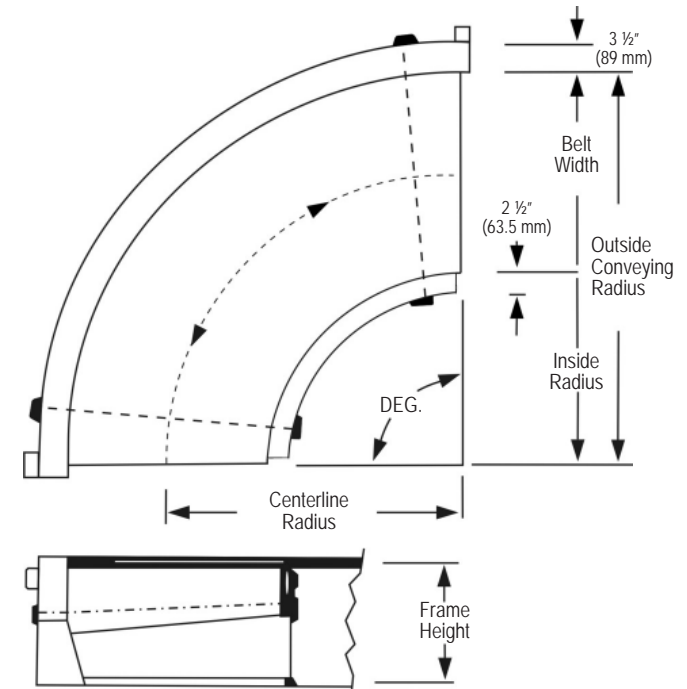
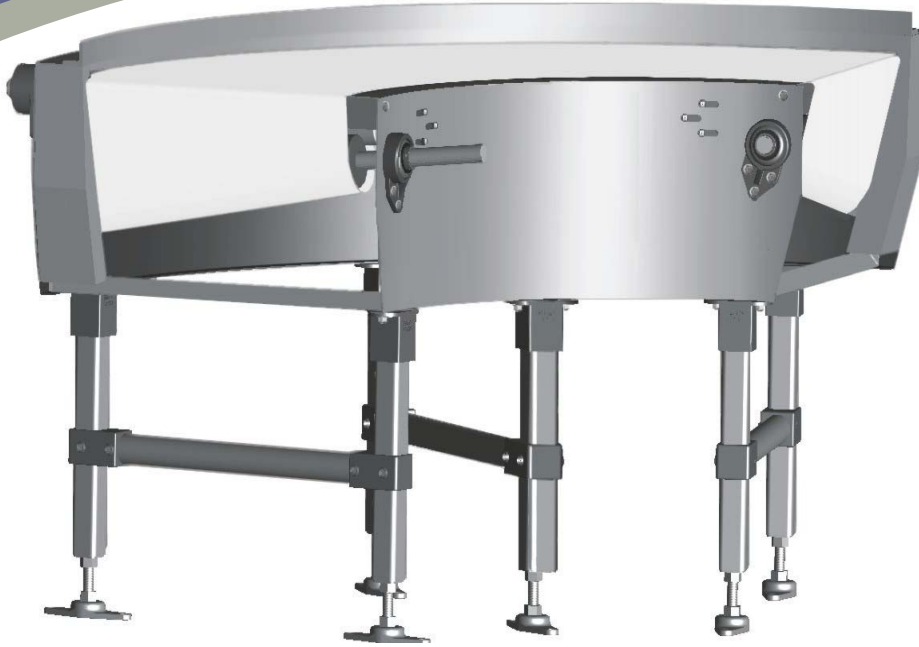

Features / Benefits

- 5/8" diameter fixed position end rolls for outstanding product transfer
- Maintains product orientation through the curve
- External bearings for easy maintenance
- Low belt tension for long component life
- Rugged steel construction
- Belt supported by steel slider bed for low friction and product support along its entire surface
- Unaffected by changes in loading, temperature or humidity
- Contaminants on the belt will not cause slippage of the belt
- Drive package can be located on outside or inside radius
- Wide variety of stainless steel finishes available

Specifications

- Loads up to 15 lbs/ft (6.8 kg/linear m)
- Belt speeds up to 120 fpm / .61 mps
- Conveying widths from 10" to 49" (between sideguards)
- Arcs from 23° to 180°
- Frame sides and slider bed are 10 gauge (3.42 mm) steel
- Welded .19" (4.83) mm angle steel crossmembers
- Sideguard construction is 14 gauge (1.89 mm) steel rolled to contour with 3/4" (19.05mm) flange top, angle out
- FDA food grade belting is standard; static conductive belting is available
- Reducer with double shaft seals available for washdown construction

ISO 9001:2000 PS-80 Rev10 05/09