



Portec Flomaster
One Forge Road (81212)
PO Box 589
Cañon City, CO 81215-0589 USA
Tel.: +1-719 275-7471
Fax: +1-719 269-3750
Email: sales@portec.com
Website: www.portec.com

C-STRAIGHT

CONVEYOR

Straight Belt Conveyor

OWNER'S MANUAL

Conveyor Location: _____

Model Number: _____

Serial Number: _____

Year of Manufacture: _____

TABLE OF CONTENTS

	Page
Section I. Conveyor Safety Precautions	3
Section II. Tool Requirements for Conveyor Installation, Maintenance, & Belt Replacement	5
Section III. Preventive Maintenance	6
• Inspection & Service Schedule	7
Section IV. Belt Adjustments	8
Section V. Belt Replacement Procedure	9
Section VI. Illustrated Parts Diagram	10
Section VII. Spare Parts List	11
Section VIII. Terms and Conditions	12

Section I

CONVEYOR SAFETY PRECAUTIONS

Portec Flomaster does not install conveyors, therefore, it is the responsibility of the contractor, installer, owner and user to install, maintain and operate the conveyor, components and conveyor assemblies in such a manner as to comply with all national, state and local laws and ordinances, including the Occupational Safety and Health Act, and the American National Standards Institute (ANSI) B20.1 Safety Code and Z244 Lockout/Tagout.

In order to avoid an unsafe or hazardous condition, the conveyors or parts must be installed and operated in accordance with the following minimum provisions.

1. Conveyors shall not be operated unless all covers and/or guards for the conveyor and drive unit are in place. If the conveyor is to be opened for inspection cleaning, maintenance or observation, the electric power to the motor driving the conveyor must be LOCKED OUT/TAGGED OUT in such a manner that the conveyor cannot be restarted by anyone; however remote from the area, until conveyor cover or guards and drive guards have been properly replaced.
2. If the conveyor must have an open housing as a condition of its use and application, the entire conveyor is then to be guarded by a railing or fence in accordance with the current revision ANSI standard B20.1.
3. Do not attempt any maintenance or repairs of the conveyor until power has been LOCKED OUT/TAGGED OUT.
4. Always operate conveyor in accordance with these instructions and those contained on the caution labels affixed to the equipment.
5. Do not place hands, feet, or any part of your body, in the conveyor.
6. Never walk on conveyor covers or guards. Never climb, sit, stand, or work from a conveyor.
7. Do not use conveyor for any purpose other than that for which it was intended.
8. Do not poke or prod material into the conveyor with a bar or stick inserted through the openings.
9. Keep the area around conveyor drive and control station free of debris and obstacles.
10. Eliminate all sources of stored energy (materials or devices that could cause conveyor components to move without power applied) before opening the conveyor
11. Do not attempt to clear a jammed conveyor until power has been LOCKED OUT/TAGGED OUT.
12. Do not attempt field modification of conveyor or components without prior approval of Portec Flomaster.
13. Conveyors are not normally manufactured or designed to handle materials that are hazardous to personnel. These hazardous materials include those that are explosive, flammable, toxic or otherwise dangerous to personnel. Conveyors may be designed to handle these materials. If hazardous materials are to be conveyed, Portec Flomaster should be consulted prior to any modifications.
14. When two or more conveyors are interfaced or joined together, make sure there is adequate guarding, pinch point protection and safety devices.
15. Only trained operators should be permitted to operate and maintain conveyors. Training needs to include instruction in operation under normal conditions and emergency conditions.
16. All starting and stopping devices should be clearly marked and the immediate area kept clear of obstructions to permit ready access.
17. The areas around loading and unloading points should be kept clear of any obstructions.

18. A person should NOT PERMITTED TO RIDE on any conveyor not specifically designed and approved to convey people.
19. Workers working around or operating conveyors should be shown the location of the starting and stopping devices and instructed how to use them to stop the conveyor in an emergency.
20. Do not use a conveyor for any purpose other than that for which it was intended. A conveyor should only be used to transport material it is capable of handling safely.
21. Under no circumstances should safety guarding or labels attached to the conveyor be altered or removed without written permission from the owner/manufacturer. If the labels attached to the equipment become illegible, order replacement warning labels from Portec Flomaster or Conveyor Equipment Manufacturer's Association (CEMA) at www.cemanet.org.
22. Routine inspections and Preventive and Corrective maintenance programs should be conducted to ensure that all safety features and devices are in place and functioning properly.
23. Employees should be alerted to the potential hazard of entanglement in conveyors caused by items such as long hair, loose clothing, and jewelry.
24. As a general rule, conveyors should not be cleaned while in operation. Where proper cleaning requires the conveyor to be in motion and a hazard exists, personnel should be made aware of all associated hazards as indicted above and take proper precautions.
25. If the conveyor is equipped with pneumatic systems, LOCK-OUT/TAG OUT the air supply before attempting any maintenance, such as changing filters.

Additional Safety Notes:

Disconnecting and locking out the power to the motor driving the unit provides the only real protection against injury. Secondary safety devices are available; however, the decision as to their need and the type required must be made by the owner-assembler as Portec Flomaster has no information regarding plant wiring, plant environment, the interlocking of the conveyor with other equipment, extent of plant automation, etc. Other devices should not be used as a substitute for locking out the power prior to removing guards or covers. We caution that use of the secondary devices may cause employees to develop a false sense of security and fail to lock out power before removing covers or guards. This could result in a serious injury should the secondary device fail or malfunction.

Electrical controls, machinery guards, railings, walkways, arrangement of installation, training of personnel, etc., are necessary ingredients for a safe working place. It is the responsibility of the contractor, installer, owner and user to supplement the materials and services provided by Portec Flomaster to make the conveyor installation comply with the law and accepted standards.

Examples of Safety Labels used on conveyors:



Section II

Tool Requirements for Conveyor Installation, Maintenance, and Belt Replacement

Tool	Used For
15 mm, 17 mm or 9/16" Wrench	Take-up Roll Tensioners
15 mm or 9/16" Wrench or Socket	Bearing Housing to Frame 1-3/16" (30 mm) dia shaft & smaller
18 mm or 3/4" Wrench or Socket	Bearing Housing to Frame 1-7/16" (35 mm) dia shaft & larger
Socket Wrench Set with 3/8" drive and imperial and/or metric sockets	Standard Drive Arrangements Slider Bed Removal
5/32" Allen Wrench	End Rolls
5/32" Allen Wrench	Bearing to Shaft 1-7/16" (35 mm) dia. shaft & larger
1/8" Allen Wrench	Bearing to Shaft 1-3/16" (30 mm) dia. shaft & smaller
3/32" Allen Wrench	Return Wheels
Electricians Nut Driver Set Or Adjustable Wrench	Electrical Motor Connections

NOTE: Only trained personnel should perform all required work on the conveyor to prevent any danger to operators or other persons, and to prevent damage to the conveyor.

WARNING: Disconnect and lock-out power before performing any installation or maintenance procedures. All guards must be in place before startup of conveyor.

Section III Preventive Maintenance

Perform a complete conveyor inspection after the first 40 hours of operation.

- Check belt tracking and tension.
- Check drive components for alignment and check that all fasteners are secure.

A Portec conveyor may be provided with regreaseable bearings at the drive roll. Lubricate at the same time as other system conveyors, which are typically on a quarterly service interval. A lithium based grease of a NLGI #2 consistency is recommended for most situations.

NOTE: No other lubrication is required on the conveyor.

Maintain the lubrication of the gearbox and drive chain (if equipped) according to the manufacturer's recommendations.

Keep the area between the conveyor belt and bedplate relatively free from debris. Excessive debris may cause premature belt wear.

WARNING: Always disconnect the power and perform the appropriate lock-out/tag-out procedures before beginning service or maintenance on the conveyor.

Inspection & Service Schedule

Component(s)	Service Interval	Task(s)	Comments
Conveyor	Monthly	Check belt tracking.	Adjust position if required.
		Check belt tension.	To tighten belt, adjust the position of the take-up roll.
		Check belt condition.	Observe overall condition for fraying, cuts, gouges, seams, etc.
		Check drive components alignment/performance.	Adjust if required.
		Check that all fasteners and hardware are secure.	Tighten if required. Do not operate unless secure.
		Check that all guards are securely in place and properly adjusted.	Readjust for clearances and secure.
Belt	Quarterly	Check for belt and seam damage.	Repair or replace as needed.
End Roll	Quarterly	Check end roll bearings for noise and lubrication.	Lubricate or replace as needed.
		Check end roll alignment.	Adjust if required.
		Check drive roll assembly location and ensure that the set screws are tight.	Adjust/tighten if required.
		Check shafts for condition with no visible damage.	If shaft is damaged from spinning in loose bearing collar or sprocket, replace as needed.
Drive Arrangement	Quarterly	Check drive sprockets/chain or v-belts for wear.	Replace as needed.
		Check motor/reducer or gear motor for noise.	Adjust if required or replace as needed.
		Check chain or belt tension.	Adjust if required.
		Check gear box lubrication level.	Refer to manufacturer's specifications.
Return Rollers	Semi-Annually	Check return rollers for noise.	Replace as needed.
		Check to ensure that return rollers are in contact with belt.	Adjust if required.
		Check that return rollers turn freely when in contact with belt.	Replace as needed.

Section IV Belt Adjustments

Drive Roll Adjustment

Position the Drive Roll (C-3) so it is perpendicular to the conveyor side frame and parallel to the conveyor bed surface. The Drive Roll may be positioned for optimal product transfer. The Drive Roll should not be adjusted for belt tension or belt tracking.

Belt Tension Adjustment

The belt tension is adjusted by moving the Non-Drive Roll (C-6) with the Take-up Bearing Unit (C-8). Belt tension should be enough to make the belt conform to the crown of the end rollers.

Note: Do not attempt to remove cupping on the edge of the belt by increasing belt tension.

Belt Tracking Adjustment:

Belt tracking is normally controlled by adjustments to the Take-up Bearing Unit (C-8). On some long conveyors, the Return Rolls (C-9) may also be used to control tracking.

1. Set the Non-Drive Roll (C-6) so it is perpendicular to the conveyor side frames and parallel to the conveyor bed surface.
2. Adjust one side of the Non-Drive Roll until the belt is centered in the conveying path. If the belt runs to one side of the conveying path, increase the belt tension slightly on that side of the conveyor belt to bring the belt into the center of the conveying path. After making a small adjustment to the Non-Drive Roll, wait until the adjustment has had its full effect on the belt before making further adjustments. It is very easy to over-adjust.

Section V

Belt Replacement Procedure

Removing the Conveyor Belt – Vulcanized Endless Belt

1. Isolate the electrical supply.
2. Separate the drive unit from the drive roll. If the conveyor uses a V-belt, chain or timing belt to drive the drive roll, simply remove the belt or chain from the drive shaft. If the conveyor has a shaft-mounted gear reducer, it will be necessary to move the gear reducer from the drive shaft.
3. Loosen the Take-up Bearing Unit (C-8).
4. Remove the Return Rolls (C-9).
5. Remove the Frame Cross Braces (C-13).
6. Remove the floor support mounting bolts on one side of the conveyor frame
7. Lift up one side of the conveyor slightly and slide the conveyor belt off the side of the conveyor.

Removing the Conveyor Belt – Laced Belt

1. Isolate the electrical supply.
2. Separate the drive unit from the drive roll. If the conveyor uses a V-belt, chain or timing belt to drive the drive roll, simply remove the belt or chain from the drive shaft. If the conveyor has a shaft-mounted gear reducer, it will be necessary to move the gear reducer from the drive shaft.
3. Loosen the Take-up Bearing Unit (C-8)
4. Remove the lacing pin from the belt seam lacing and remove the old belt.

Installing the Conveyor Belt:

Installing a conveyor belt is done in the opposite sequence of removing the belt. After installing the conveyor belt, adjust the belt for tension and tracking.

Note: Before installing the belt, check all parts for wear and/or damage. Replace any parts as necessary.

Section VI
Illustrated Parts Diagram — C-Straight Conveyor

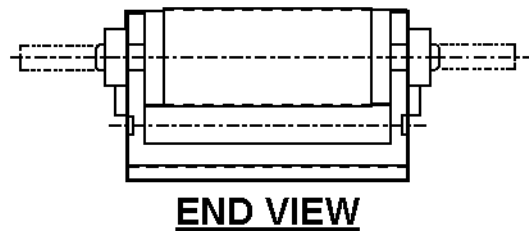
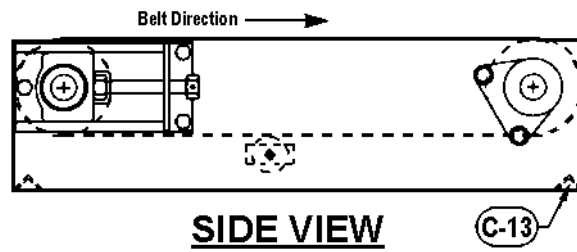
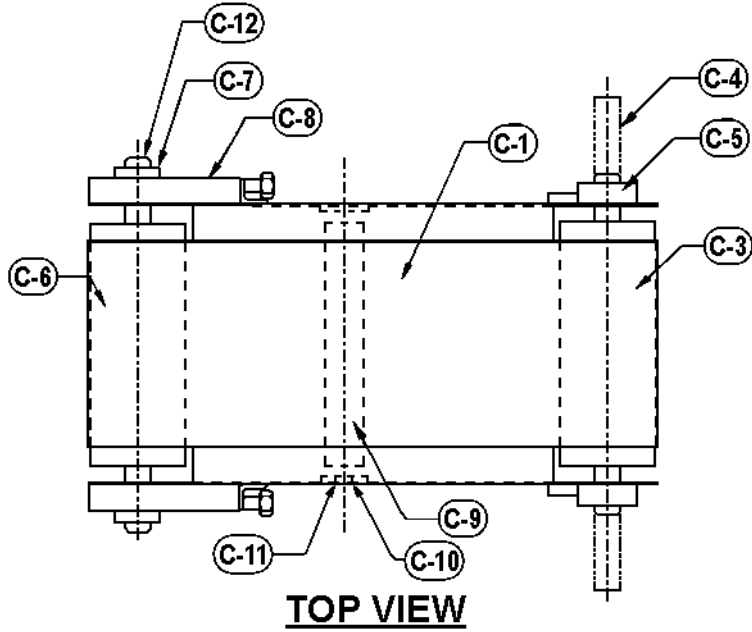

<h2 style="margin: 0;">Section VII</h2> <h1 style="margin: 0;">C-STRAIGHT CONVEYOR – SPARE PARTS LIST</h1>
--

Please supply the following information when ordering or corresponding with us regarding replacement parts for your Portec C-Straight Conveyor: **SERIAL NUMBER and MODEL NUMBER from the name plate on the conveyor, and PORTEC ITEM NUMBER corresponding to your requirement from the illustrated Parts Diagram.** The Serial Number (or the specific part number, if known) will ensure an equivalent replacement. To obtain any part not listed or shown, please consult our Parts Department at +1(719) 275-7471 extensions 220 or 253.

ITEM	PART DESCRIPTION	PORTEC PART NO.
C-1	CONVEYOR BELT – VULCANIZED ENDLESS OR LACED	
C-3	DRIVE ROLL (LAGGED)	
C-4	DRIVE ROLL SHAFT	
C-5	DRIVE ROLL BEARINGS	
C-6	NON-DRIVE ROLL	
C-7	NON-DRIVE ROLL BEARINGS	
C-8	TAKE-UP BEARING UNIT	
C-9	RETURN ROLL WITH BEARINGS	
C-10	RETURN ROLL SHAFT (7/16" HEX)	
C-11	RETURN ROLL HANGER	
C-12	NON-DRIVE ROLL SHAFT	
C-13	FRAME CROSS BRACE	

TERMS AND CONDITIONS

VALIDITY – Quotations shall be considered current if outstanding no more than thirty (30) days from date of quotation, unless otherwise stated on quotation.

FREIGHT POLICY – Shipments of products, unless otherwise stated, is EX WORKS PORTEC FLOMASTER'S factory. Written claims for damage in shipment should be made against the carrier. Written claims for shortages should be made against the carrier, specifically if there is evidence of shipping carton/container damage and/or if according to the shipping records there is a discrepancy in numbers of containers shipped versus numbers received.

Only in a situation where the container(s) shipped have been received in good condition, checked for physical content, and signed for verification within three days of delivery, and if such shortage has been found, and if PORTEC FLOMASTER® is notified in writing within 10 days upon receipt of order, PORTEC FLOMASTER will establish that there was or was not a shortage. If a shortage is determined, PORTEC FLOMASTER will provide the customer with the product/parts at PORTEC FLOMASTER'S expense and shall ship F.O.B. as stated in the freight policy. If no shortage is determined, or if others than PORTEC FLOMASTER caused the shortage, the claim shall be deemed invalid and it shall be the responsibility of the customer to arrange payment to PORTEC FLOMASTER to fill the requirements of the deficiency.

PRICE ACCEPTANCE – The prices quoted herein are based on the quantities specified. Any change in quantities may affect quoted price. All orders are subject to acceptance at PORTEC FLOMASTER'S factory. Any expense incurred by PORTEC FLOMASTER as a result of cancellation or the making of any change will be included in PORTEC FLOMASTER'S invoice unless prior waiver of such expense is obtained from PORTEC FLOMASTER.

SHIPMENTS – Quoted Shipment dates are subject to change, without liability for delays beyond PORTEC FLOMASTER'S control.

TERMS OF PAYMENT – Invoices are payable net cash 30 days, unless otherwise noted. There will be an interest charge of 1-1/2% per month for all payments received after 35 days. International (**except Canada**) orders are shipped against confirmed irrevocable letters of credit. All payments shall be in U.S. dollars. If the financial responsibility of a purchaser becomes impaired or is unsatisfactory, or if credit is not established, PORTEC FLOMASTER reserves the right to request payment in advance or satisfactory guarantee that invoices will be paid promptly when due.

QUALITY ASSURANCE – All of its manufactured products are subject to PORTEC FLOMASTER'S Warranty for material and workmanship.

GENERAL – Terms conditions, and product specifications are subject to change without further obligation to PORTEC FLOMASTER.

LIMITED WARRANTY ON NEW EQUIPMENT – PORTEC FLOMASTER provides a Limited Warranty that warrants the material and workmanship of its manufactured products, with exceptions noted, for a period for 24 months beginning one month from the date of shipment from PORTEC FLOMASTER'S factory, according to recorded serial numbers.

Within the stated warranty period, any material or workmanship showing defects will be repaired or replaced,

provided PORTEC FLOMASTER is given written notice within 30 days after failure, and a willingness is expressed to submit the product to PORTEC FLOMASTER, and if PORTEC FLOMASTER authorizes the return of the product, and the product is returned. This warranty does not cover against normal wear of parts or materials. Warranty parts are supplied via EX WORKS PORTEC FLOMASTER'S factory and unless PORTEC FLOMASTER makes express agreement the purchaser shall bear the expense of installation. PORTEC FLOMASTER reserves the right at any time to supervise or install any part of replacement, or supervise adjustment incident to satisfactory operation of equipment. *A possible Warranty PO for parts and/or service may be required prior to shipping parts or exercising warranty labor.*

ITEMS IDENTIFIED AS COMPONENT AND REPLACEMENT PARTS – will be warranted for a period of one (1) year from the date of shipment from the PORTEC FLOMASTER Factory. This warranty on parts will cover only defects in workmanship or material. The warranty *does not cover the costs of the installation of such parts unless authorized by the designated PORTEC FLOMASTER representative.*

Unauthorized returns, modifications, additions or variations, from procedures and information contained in PORTEC FLOMASTER'S Owner's Manuals, and Product Data bulletins, or any misuse, negligence, accident, product jam, or loading beyond rated capacity invalidates this warranty.

EXCEPTIONS:

1. Because of varying operating conditions, all belting supplied will necessarily be subject to manufacturers', warranty rather than that of PORTEC FLOMASTER.
2. Some OEM equipment including motors and gear reducers will be subject to the manufacturer's warranty, not PORTEC FLOMASTER'S. PORTEC FLOMASTER Customer & Product Support will provide assistance in contacting the proper manufacturer's representative. If a replacement is provided from PORTEC FLOMASTER stock, a Possible Warranty PO must be provided. If the warranty is deemed invalid and PORTEC FLOMASTER is not reimbursed for the warranty claim, the PO will be exercised.
3. PORTEC FLOMASTER further reserves the right to void its warranty where final destination and specific application are withheld; product is improperly installed or maintained by others; product is modified without the consent from the designated PORTEC FLOMASTER service representative; product is improperly protected against hazards and adverse environmental conditions during storage prior to or during installation; and/or product is used for applications/conditions other than indicated upon placement of order.

The foregoing warranty is exclusive and in lieu of all other warranties whether written, oral, or implied (including any warranty of merchantability or fitness for any purpose). Under no circumstances shall PORTEC FLOMASTER be liable for incidental or consequential damages. The foregoing warranty cannot be changed except by written authorization signed by an authorized PORTEC FLOMASTER representative, and no attempt to repair or promise to repair or improve PORTEC FLOMASTER products by any other representative of PORTEC FLOMASTER shall change or extend said warranty in any manner whatsoever.