

OWNER'S MANUAL

BELT MERGE[®]

SINGLE AND DOUBLE CHAIN BELT MERGE CONVEYORS

PORTEC FLOMASTER

P.O. BOX 589

CAÑON CITY, COLORADO 81215-0589 USA

Telephone: +1(719) 275-7471

Fax: +1(719) 269-3750

www.portec.com

Conveyor Location: _____

Model Number: _____

Serial Number: _____



MAINTENANCE AND INSPECTION

- Belt adjustment
- Belt replacement
- Chain adjustment
- Installation procedures
- Preventative maintenance
- Troubleshooting
- Parts list
- Warranty

NOTICE

- Make sure **ALL** guards are in place before operating machine.
- Make sure power is off before working on machine.
- Keep hands and loose clothing away from drive components while machine is in operation.

© 1997 Portec, Inc.
PS-67 REV-3 6/07



Table of Contents

SECTION	PAGE
1. General description of BELT MERGE conveyors	3
2. Application suggestions	3
3. Safety precautions	4
4. Installation instructions	6
a. Assembly & Setup: Conveyors with multi-section frame	6
b. Assembly & Setup: Conveyors with one piece frame	10
5. Service and Maintenance	12
a. Visual checks	12
b. Fasteners	12
c. Adjusting chain tension	12
d. Adjusting chain & sprocket timing: Double chain only	14
e. Belt replacement	15
f. Replacing broken attachment links	17
g. Chain assembly lubrication	18
h. Chain guide strip replacement	19
i. Drive unit	21
Gear reducer	21
Motor & drive unit mounts	21
6. Troubleshooting guide	22-23
7. Preventative maintenance schedule	24
8. Spare parts list	25
9. Recommended spare parts list	26
10. Illustrated parts diagram	27-31
11. Terms & Conditions	32

1. General Description of ***BELT MERGE*** Conveyors

The Belt Merge conveyor is an all-steel straight conveyor designed to facilitate the merging of two or more conveyor lines into a single product transport line and overcome belt tracking problems associated whenever a short wide conveyor belt is used.

The Belt Merge conveyor eliminates side load belt tracking problems encountered on regular belt conveyors by utilizing a belt drive chain. Unlike most straight conveyors, the Belt Merge conveyor does not use the end roll to drive its conveyor belt. The belt is pulled along by its outside edge by the belt drive chain. A special chain attachment link connects the belt drive chain to a series of grommets along the edge of the belt. The belt drive chain runs in a track along the side of conveyor and holds the belt in the correct position. A single chain Belt Merge conveyor (CSC) has a drive chain on one side of the belt and allows the conveyed product to be diverted in only one direction. A double chain Belt Merge conveyor (CDC) has a drive chain on both edges of the belt and allows the conveyed product to be diverted to either side of the conveyor.

2. Application Suggestions

Certain chemicals and oils can decrease the belt life significantly. If you have a potential problem, please consult the factory.

Repeated hard starts have a tendency to reduce the belt and drive component life. Due to this shock action, a soft start device is recommended to allow the drive mechanism to be softened.

1. Set the potentiometer low and increase gradually to desired settings.
2. Do not set higher than is necessary to obtain desired performance.

When start/stops exceed 8 per minute, it is recommended that a clutch be used to allow the motor to run continuously and cool properly.

3. Safety and Operation Precautions

Portec Flomaster does not install conveyors, therefore, it is the responsibility of the contractor, installer, owner and user to install, maintain and operate the conveyor, components and conveyor assemblies in such a manner as to comply with all national, state and local laws and ordinances, including the Occupational Safety and Health Act, and the American National Standards Institute (ANSI) B20.1 Safety Code and Z244 Lockout/Tagout.

In order to avoid an unsafe or hazardous condition, the conveyors or parts must be installed and operated in accordance with the following minimum provisions.

- a) Conveyors shall not be operated unless all covers and/or guards for the conveyor and drive unit are in place. If the conveyor is to be opened for inspection cleaning, maintenance or observation, the electric power to the motor driving the conveyor must be LOCKED OUT/TAGGED OUT in such a manner that the conveyor cannot be restarted by anyone; however remote from the area, until conveyor cover or guards and drive guards have been properly replaced.
- b) If the conveyor must have an open housing as a condition of its use and application, the entire conveyor is then to be guarded by a railing or fence in accordance with the current revision ANSI standard B20.1.
- c) Do not attempt any maintenance or repairs of the conveyor until power has been LOCKED OUT/TAGGED OUT.
- d) Always operate conveyor in accordance with these instructions and those contained on the caution labels affixed to the equipment.
- e) Do not place hands, feet, or any part of your body, in the conveyor.
- f) Never walk on conveyor covers or guards. Never climb, sit, stand, or work from a conveyor.
- g) Do not use conveyor for any purpose other than that for which it was intended.
- h) Do not poke or prod material into the conveyor with a bar or stick inserted through the openings.
- i) Keep the area around conveyor drive and control station free of debris and obstacles.
- j) Eliminate all sources of stored energy (materials or devices that could cause conveyor components to move without power applied) before opening the conveyor
- k) Do not attempt to clear a jammed conveyor until power has been LOCKED OUT/TAGGED OUT.
- l) Do not attempt field modification of conveyor or components without prior approval of Portec Flomaster.
- m) Conveyors are not normally manufactured or designed to handle materials that are hazardous to personnel. These hazardous materials include those that are explosive, flammable, toxic or otherwise dangerous to personnel. Conveyors may be designed to handle these materials. If hazardous materials are to be conveyed, Portec Flomaster should be consulted prior to any modifications.
- n) When two or more conveyors are interfaced or joined together, make sure there is adequate guarding, pinch point protection and safety devices.
- o) Only trained operators should be permitted to operate and maintain conveyors. Training needs to include instruction in operation under normal conditions and emergency conditions.
- p) All starting and stopping devices should be clearly marked and the immediate area kept clear of obstructions to permit ready access.
- q) The areas around loading and unloading points should be kept clear of any obstructions.
- r) A person should NOT BE PERMITTED TO RIDE on any conveyor not specifically designed and approved to convey people.
- s) Workers working around or operating conveyors should be shown the location of the starting and stopping devices and instructed how to use them to stop the conveyor in an emergency.

- t) Do not use a conveyor for any purpose other than that for which it was intended. A conveyor should only be used to transport material it is capable of handling safely.
- u) Under no circumstances should safety guarding or labels attached to the conveyor be altered or removed without written permission from the owner/manufacturer. If the labels attached to the equipment become illegible, order replacement warning labels from Portec Flomaster or Conveyor Equipment Manufacturer's Association (CEMA) at www.cemanet.org.
- v) Routine inspections and Preventive and Corrective maintenance programs should be conducted to ensure that all safety features and devices are in place and functioning properly.
- w) Employees should be alerted to the potential hazard of entanglement in conveyors caused by items such as long hair, loose clothing, and jewelry.
- x) As a general rule, conveyors should not be cleaned while in operation. Where proper cleaning requires the conveyor to be in motion and a hazard exists, personnel should be made aware of all associated hazards as indicted above and take proper precautions.

Additional Safety Notes:

Disconnecting and locking out the power to the motor driving the unit provides the only real protection against injury. Secondary safety devices are available; however, the decision as to their need and the type required must be made by the owner-assembler as Portec Flomaster has no information regarding plant wiring, plant environment, the interlocking of the conveyor with other equipment, extent of plant automation, etc. Other devices should not be used as a substitute for locking out the power prior to removing guards or covers. We caution that use of the secondary devices may cause employees to develop a false sense of security and fail to lock out power before removing covers or guards. This could result in a serious injury should the secondary device fail or malfunction.

Electrical controls, machinery guards, railings, walkways, arrangement of installation, training of personnel, etc., are necessary ingredients for a safe working place. It is the responsibility of the contractor, installer, owner and user to supplement the materials and services provided by Portec Flomaster to make the conveyor installation comply with the law and accepted standards.

Examples of Safety Labels used on conveyors:

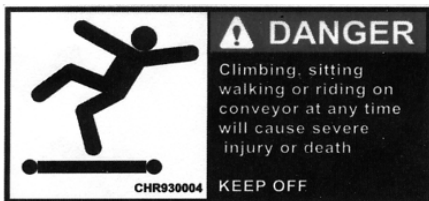

4. Installation Instructions

Belt Merge conveyors are normally shipped partially disassembled. The drive unit, floor supports and sideguards will have to be attached to the conveyor unit. Larger-sized conveyors are normally shipped in several sections and will have to be assembled in the field.

4a. Assembly & Setup: Conveyors with Multi-Section Frame

Conveyors that have been manufactured in two or more sections will have to be assembled on site. After uncrating the conveyor and moving it to the site, the assembly process may begin.

1. Arrange the sections so the end rolls are at the ends. Middle sections should be placed in order between the end sections.
2. Raise one end section and attach the floor supports and braces.
Note: Never lift a conveyor by the drive shaft extension or shaft deflection can result.
3. While supporting the end section in place, raise the next section and bolt it to the end section using pre-drilled plates below the slider bed and on the lower side of the frames. (Portec does not recommend attempting to lift a large conveyor in one piece due to potential damage to the conveyor at the joints between sections.)
Note: Use a straight edge to insure that the slider bed is flat at the joints. A slight step down situation in the direction of the belt travel is permissible. A step-up situation in the direction of the belt travel will cause damage to the belt and lacing.

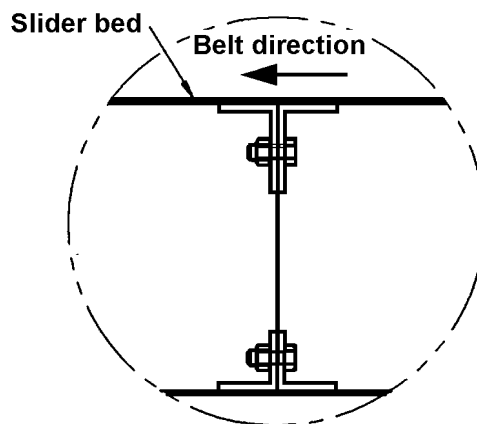

4. After bolting together the remaining end piece, the remaining floor supports and braces should be attached using the bolts provided.
5. After the frame is assembled and floor supports attached, position the conveyor in relation to the adjoining conveyors. Level the conveyor and securely attach to the floor. It may be necessary to shim the legs if the floor is uneven.
6. Apply a 1/4" (6 mm) bead of Lubriplate Mulith#2 grease in the groove of each vertical wear guide for the length of the conveyor.

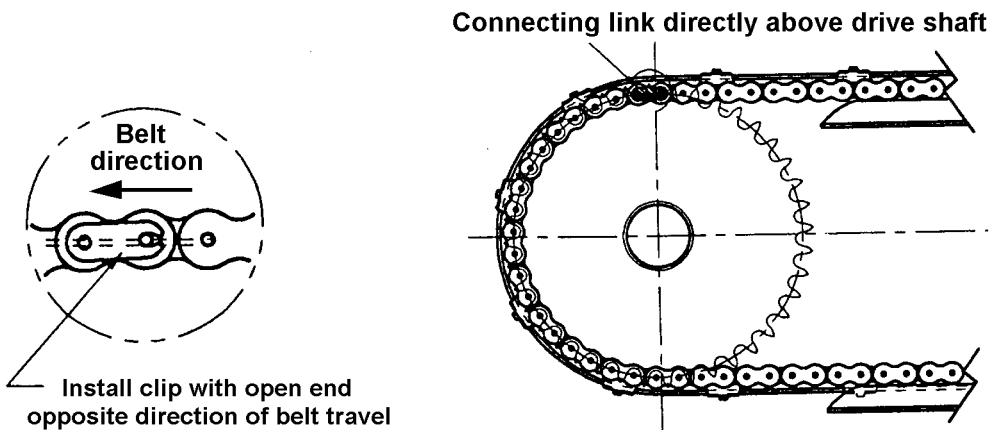

7. Thread the belt and chain onto the conveyor and connect the chain using the special connecting link provided and connect the belt lacing using the lacing pin provided. When installing the belt on a double chain model, it is critical that the sprockets are "in time". To time the sprockets, match the master links of the chain at the same point on the drive sprockets. Install the connecting link clip with the open end opposite to the direction of belt travel.

8. The take-up frames are marked at the factory for initial setup. Assure that the mark is lined up with the edge of the bearing as shown. **Future adjustments to allow for chain stretch must be done, taking care not to bring the belt tight against the roll.**

Note: Do not adjust the take-up roll to minimize the transfer distance to the adjoining conveyor. A transfer roll can be used to minimize the transfer distance.

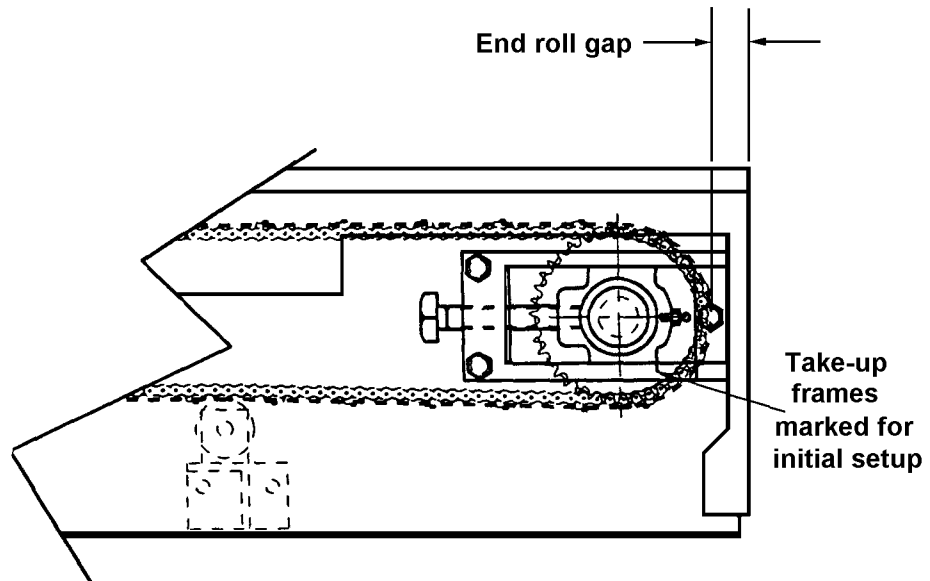

9. Place a straight edge across the face of the conveyor end to verify a consistent end roll gap. It is also possible to check the end roll gap by measuring the positions of the bearings in the take-up frame. When adjusting the end roll, be careful not to bring the belt tight against the end roll.

WARNING: A CONVEYOR THAT HAS AN UNEVEN END ROLL GAP OR THAT IS ADJUSTED WITH THE BELT TIGHT AGAINST THE ROLL WILL DAMAGE THE EQUIPMENT AND MAY BECOME HAZARDOUS.

10. Inspect the chain tension after setup. Attempt to maintain the initial tension when making future adjustments. Chain tension should be checked between the end roll sprocket and the end of the chain guide strips on the top side of the conveyor. Adjust the position of the end rolls to adjust chain tension.

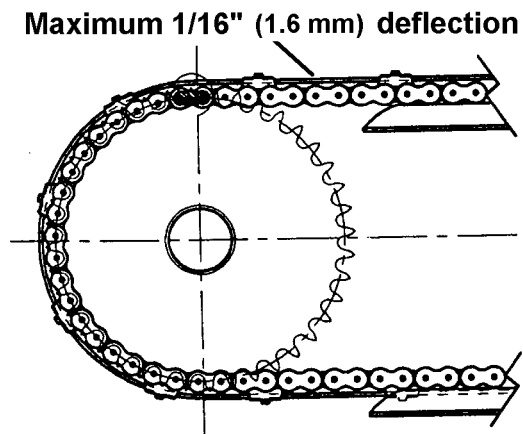

11. Mount the drive unit on the discharge end drive shaft extension.
12. During the initial run-in period listen for any unusual noises and observe the belt to insure that it is not rubbing against any other parts such as the conveyor sideguards, chain cover or the adjoining conveyor. Some small adjustments may be necessary and are described in further detail in this manual. The first semi-annual check should be made after the first 40 hours of operation. (See the Preventative Maintenance Schedule p. 24)

Note: Do not stand or place any heavy weight on the chain cover or sideguards. They may bend down and contact the belt resulting in damage to the belt.

4b. Assembly & Setup: Conveyors with One Piece Frame

Portec Belt Merge conveyors with a one-piece frame have been fully assembled, adjusted and shop tested before being shipped. Only minor checking is required to insure that no parts may have shifted during shipment. The floor supports, sideguards and drive unit are normally removed for shipment. After uncrating the conveyor and moving it to the site, the assembly process may begin.

1. Raise the conveyor and attach the floor supports and braces using the bolts provided. Be sure to observe all safety precautions when working under hoisted equipment.
Note: Never lift a conveyor using the drive shaft extension or shaft deflection can result.
2. Position the conveyor in relation to the adjoining conveyors. Level and securely attach the conveyor to the floor. It may be necessary to shim the legs if the floor is uneven.
3. Mount the drive unit on the discharge end drive shaft extension. The drive unit is not normally supplied with a motor starter or other controls.
4. Before startup, check to be sure that the belt is not rubbing against any other part such as a conveyor sideguard, chain cover or an adjoining conveyor.

5. Place a straight edge across the face of the conveyor end to verify a consistent end roll gap. It is also possible to check the end roll gap by measuring the positions of the bearings in the take-up frame. When adjusting the end roll, be careful not to bring the belt tight against the end roll.

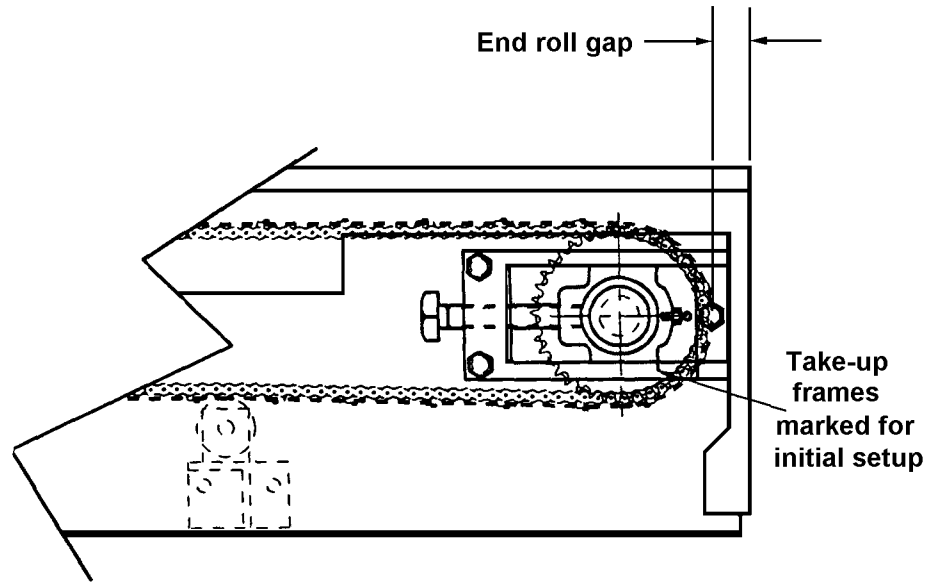

6. During the initial run-in period listen for any unusual noises that may indicate that something is out of alignment. Some small adjustments may be necessary and are described in further detail in this manual.
WARNING: Do not adjust the end rolls to minimize the transfer distance to an adjoining conveyor.
7. Inspect the chain tension after setup. Attempt to maintain the initial chain tension when making future adjustment. The first semi-annual check should be made after the first 40 hours of operation. (See the Preventative Maintenance Schedule p. 24)

Note: *Future adjustments to allow for chain stretch must be done, taking care not to bring the belt tight against the roll.*

WARNING: A CONVEYOR THAT HAS AN UNEVEN END ROLL GAP OR THAT IS ADJUSTED WITH THE BELT TIGHT AGAINST THE ROLL MAY DAMAGE THE EQUIPMENT AND BECOME HAZARDOUS.

5. Service and Maintenance

5a. Visual check: Check for any changes, rub marks, abrasion, noises, excessive dust or damage to the belt. The belt must be relatively clean and gouge free. The chain should be adjusted so it is snug, not tight. The belt should never be tight against the end roll or damage to the conveyor may result.

5b. Fasteners: Inspect all fasteners to be sure they are tight.

5c. Adjusting Chain Tension:

1. Remove the bolts that attach the chain cover to the frame. Lift off the chain cover being careful not bend or distort it.
2. Check the alignment of the sprockets. They should be located in the center of the normal chain path.
Note: Misalignment can cause premature chain and sprocket wear or cause the chain to jump the sprocket teeth.
3. Check the sprocket set screws to insure that they are tight.
4. Use a straight edge to verify that the end roll gap is consistent on all four corners of the conveyor. It is also possible to check the end roll gap by checking the positions of the bearings in the take-up frames.

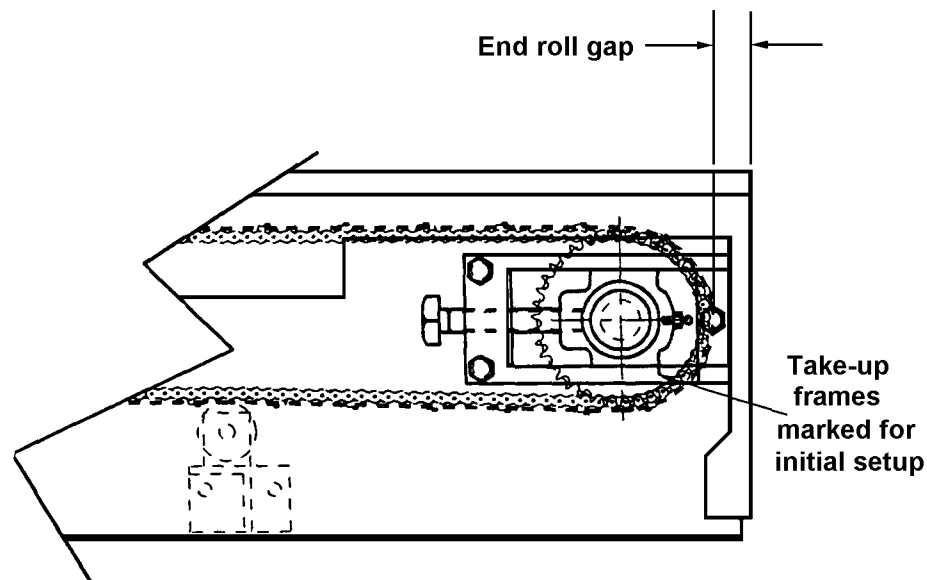

5. Check the vertical alignment of the end roll to insure that it is in line with the flat section of the slider bed.
6. Check chain tension between the end roll sprockets and the end of the chain guide strips. Adjust the position of the end rolls until the chain deflection is between $1/32$ - $1/16$ " (.8-1.6 mm).

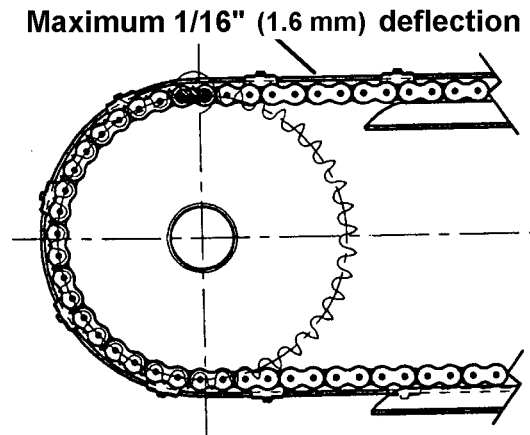

7. Return the chain cover to its position and bolt it into place.

5d. Adjusting Chain And Sprocket Timing: Double Chain Only

The Portec Belt Merge conveyor with double chains must have both chains operating in correct timing with each other.

1. Remove both chain covers to reveal the chains and sprockets on the discharge end of the conveyor.
2. Move the belt assembly forward until the special chain connecting link is directly above the drive shaft on both sides of the conveyor.
3. If one connecting link is directly above the drive shaft while the connecting link on the opposite side is not, the sprockets are “out of time”.

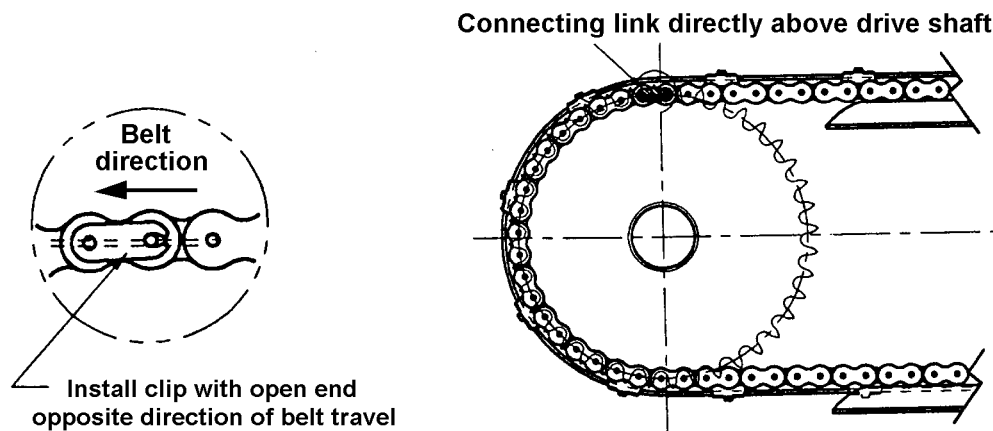

4. Disconnect one of the connecting links and lift the chain slightly away from the sprocket. It may be necessary to loosen the chain tension slightly.
5. Pull the chain forward on the sprocket until both connecting links are directly above the drive shaft.
6. Replace the special connecting link and readjust the chain tension.
Note: Install the connecting link clip with the open end opposite the direction of belt travel.
7. Replace the chain covers.

5e. Belt Replacement:

Note: The instructions are for the single chain conveyor. For a double chain conveyor, perform the same steps to both sides of the conveyor.

1. Remove the chain cover. Be careful not to bend or twist it as you lift it off.
2. Move the belt assembly forward until the special chain connecting link is near the top side of the discharge end of the conveyor.
3. Disconnect the drive unit from the end roll drive shaft in order to allow the end roll to rotate freely.
4. Loosen the chain tension slightly.
5. Remove the special connecting link from the chain.
6. Put both of the belt together and insert the lacing pin in the lacing hooks leaving some excess lacing pin on both ends.
7. Roll the belt assembly up on the top of the conveyor. Pull the belt assembly forward and continue rolling until the entire belt is rolled up. Take the belt assembly off from the conveyor.
8. Place the replacement belt on top of the conveyor. Unroll the belt with the bottom side of the belt down. Pull the end of the belt and chain over the infeed end roll of the conveyor. Insert the chain into the lower chain guide and pull the belt and chain under the conveyor. While the chain rides in the chain guides, the belt runs over the return rollers.

Note: The new belt may also be installed by attaching the end of the new belt to the end of the old belt. As the old belt is pulled off the conveyor, the new belt will be pulled under the return side of conveyor. When the new belt is completely pulled under the conveyor, the end should be disconnected from the old belt.

9. Position the ends of chain on top the sprocket at the discharge end of the conveyor.

Note for Double chain conveyors only: The chain ends on both sides of the conveyor must be directly above the discharge end drive shaft in order for both sprockets to be timed correctly.

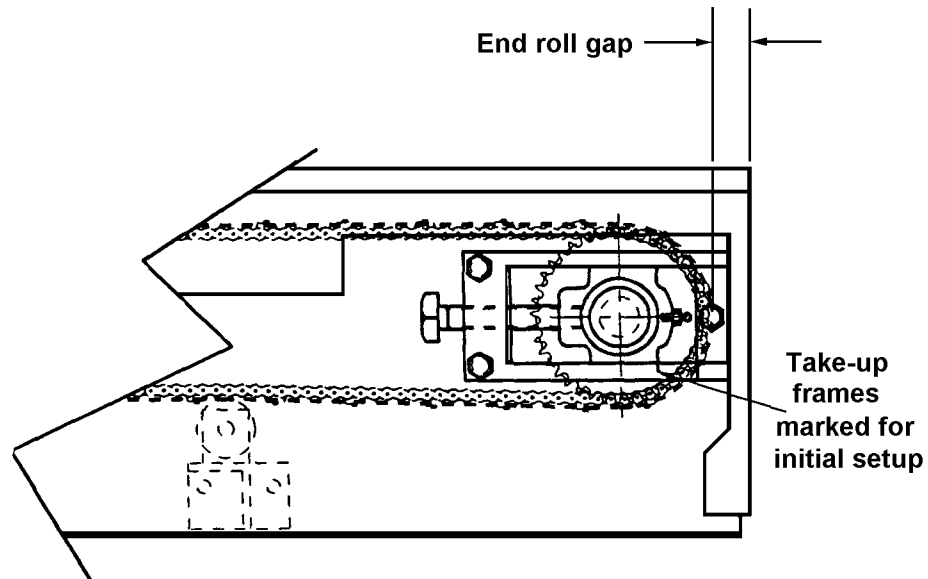

10. Connect the chain using the special connecting link. Install the connecting link clip with the open end opposite the direction of belt travel.
11. Put both ends of the belt together, align the edges of the belt, and install the lacing pin. Bend the end of the lacing pin over and insert the end of the lacing pin into the lacing hooks. Ensure that at least 1/2" (13 mm) of the lacing pin is inserted into the lacing hooks. From the opposite end of the lacing pin, pull the lacing pin taut, bend the lacing pin back and insert the end of the lacing pin into the lacing hooks. The lacing pin may have to be cut to length so that 1/2" (13 mm) of the lacing pin is inserted into the lacing hooks.
12. Readjust the chain tension.
13. Replace the chain cover.

5f. Replacing Broken Attachment Links:

If a foreign object gets caught under the chain cover, it is possible for an attachment link to break.

1. Remove the chain cover.
2. Move the belt assembly forward until the broken attachment link is on the top side of the conveyor.
3. Loosen the chain tension slightly.
4. Using a chain breaker tool, break the chain at the link before and after the broken attachment link.
5. Grind off the head of the rivet and remove the broken attachment link.
6. Inspect the belt grommet to insure that it is in good condition.
7. Install a new attachment link in the chain using a new connecting link on each side of the attachment link. Install the connecting link clip with the open end opposite the direction of belt travel.
8. Insert a new rivet, washer and nylon bushing up through the grommet hole. The top of the rivet should be inserted into the hole in the attachment link.
9. Place a heavy piece of flat steel under the rivet and peen over the top of the rivet to secure it to the attachment link. The rivet should not be peened too tightly so as to stop the nylon bushing from rotating in the grommet hole.

Note: Screw-Type two-piece rivets from Portec with thread-lock can also be used. Screw-Type rivets can easily be installed without the need for hand-peening. Contact Portec Parts Sales for Screw-Type Rivets.

10. Readjust the chain tension.
11. Replace the chain cover.

5g. Chain Assembly Lubrication:

This conveyor is equipped with grease fittings located in the frame and chain cover along the length of the chain. We recommend using Lubriplate Molith #2 grease. The frequency of lubrication and amount required will depend upon the load, speed and environmental conditions. Some general guidelines are as follows:

- Clean conditions @ 8 hours per day** - Lube every 3-4 months
- Clean conditions @ 18 hours per day** - Lube every 6-8 weeks
- Dusty conditions @ 8 hours per day** - Lube every 4-6 weeks
Clean chain every 4-6 months
- High humidity** - Lube enough to stop rust and every 4-5 weeks

Periodic chain cleaning with a solvent soaked cloth is highly recommended when operating in dusty conditions. After cleaning, apply new grease to the entire length of the chain and work it well into the moving parts.

WARNING: Running a conveyor that does not have adequate lubrication will damage the conveyor and substantially shorten the life of the chain.

Note: The grease fittings are open backed. Do not over grease.

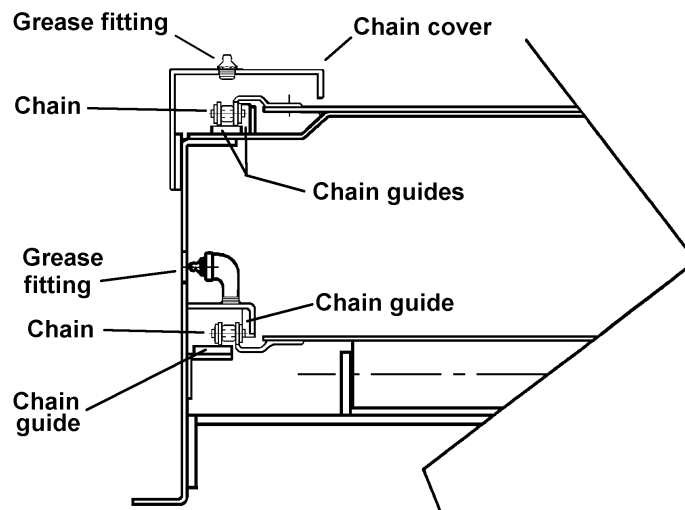

SECTION VIEW OF FRAME

5h. Chain Guide Strip Replacement:

1. Remove chain cover.
2. Remove the belt and chain assembly.
3. Remove the old guide strips. Take note of the mounting positions and spacing between the lower guide strips.

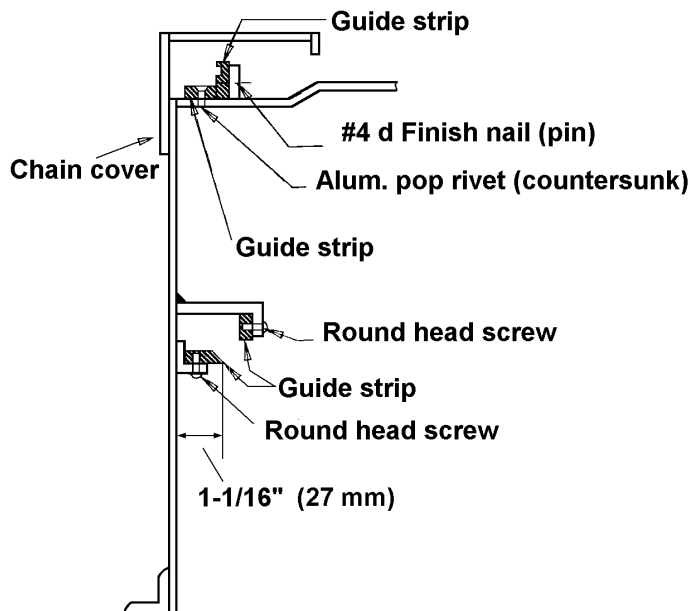

4. The lower guide strips with the 45° edge must be installed using the self tapping screws provided. (pilot hole must be drilled)
Note: When butting pieces end to end, use a fastener near the end on both pieces.
5. The lower guide strip with the rectangular profile must be spaced as shown and attached with self tapping screws provided.
6. The vertical guide strip on the top is sitting on the bed surface and is held in place with 4d finish nails acting as pins. The heads of the nails should be flush with surface of the guide and the pin snipped off if it extends beyond the metal backing.

7. The horizontal top guide strip is positioned against the vertical piece and attached with 1/8" (3.2 mm) pop rivets, which are countersunk to eliminate a protruding rivet head.
8. Contour the ends of the guide strips to a similar shape as the original guides to allow the chain to quietly enter and exit the chain guide track.
9. Replace the belt and chain assembly.
10. Lubricate the chain.
11. Readjust the chain tension.
12. Replace the chain cover.

Note: Do not stand or place any heavy weight on the chain cover or sideguards. They may bend down and contact the belt, resulting in damage to the belt.

5i. Drive Unit:

Gear reducer

1. **Mounting bolts:** The mounting bolts should be inspected periodically to ensure that they remain tight and that no misalignment has occurred.
2. **Lubricant:** The gear reducer should be checked to ensure that the lubricant level is maintained at the manufacturer's recommended level. Consult the gear reducer manufacturer or their owner's manual before adding lubricant to confirm the correct lubricant to use. Some gear reducers are permanently sealed with an internal pressure compensation device. These gear reducers normally do not need the lubricant levels checked.
3. **Vent plug:** Some gear reducers are shipped with a plastic plug in place of the vent plug. The plastic plug prevents oil from leaking during transportation. The plastic plug must be removed during the installation process and replaced with the correct vent plug. The vent plug is normally included with the package of fasteners or is fastened to the gear reducer; however, not all gear reducers are equipped with vent plugs.
4. **Temperature:** Temperature alone is not a good way to determine whether a gear reducer is going to fail. Some gear reducers are designed to operate for extended periods at elevated temperature levels that may seem excessive.

Note: Because temperature and noise levels can vary substantially between different brands or types of gear reducers, it is best to consult the gear reducer manufacturer or their owner's manual before performing maintenance on a gear reducer.

Motor and Drive Unit Mounts

The motor should be periodically checked to insure that it is not overheating, making unusual noises or vibrations. V-belt or chain drives should be properly aligned with the correct tension. All fasteners should be checked for tightness.

6. Troubleshooting Guide

Problem	Cause & Solution
Lace hooks coming out of belt	<p>1.) Slider bed joints uneven SOLUTION: Realign bed</p> <p>2.) Belt tight against end rolls and chain loose against sprockets. SOLUTION: Replace belt assembly</p> <p>3.) Lace rubbing against adjoining conveyors or foreign object. SOLUTION: Realign conveyor or remove obstruction.</p>
Problem	Cause & Solution
Sprocket and chain noises	<p>1.) Double chain merge unit sprockets out of time SOLUTION: Retime sprockets</p> <p>2.) Sprocket & chain misalignment SOLUTION: Realign sprockets</p> <p>3.) Worn chain sprockets SOLUTION: Replace sprockets</p> <p>4.) Belt or chain excessively worn SOLUTION: Replace belt assembly</p>
Problem	Cause & Solution
Groove cut or wear in belt	<p>1.) Chain cover or sideguards crushed down on belt SOLUTION: Repair or replace chain cover Replace belt if damage is severe</p> <p>2.) Contact with adjacent conveyor or foreign object SOLUTION: Remove foreign object or readjust conveyor position so nothing contacts the belt. Replace belt if damage is severe.</p>
Problem	Cause & Solution
Excessive wear on one side of the belt	<p>1.) End roll out of alignment SOLUTION: Realign end rolls</p> <p>2.) Chain guide supports bent near the end of the conveyor SOLUTION: Bend chain guide supports so that the chain exits straight off end of the conveyor.</p>

6a. Troubleshooting Guide

Problem	Cause & Solution
Premature wear of chain guide strips	1.) Sprockets out of alignment SOLUTION: Align sprockets 2.) Inadequate chain lubrication SOLUTION: Lubricate chain 3.) Uneven end roll adjustment SOLUTION: Adjust end roll
Problem	Cause & Solution
Chain slipping on sprocket	1.) Chain tension too loose SOLUTION: Adjust chain tension 2.) Sprocket damaged or badly worn SOLUTION: Replace sprocket
Problem	Cause & Solution
End roll bearing wobble or noise.	1.) Bearing failure from overtensioning SOLUTION: Replace bearing & adjust end roll position 2.) Bearing failure from lack of lubrication (regreaseable bearings only) SOLUTION: Replace bearing & increase lubrication schedule
Problem	Cause & Solution
Diagonal wrinkle in belt (double chain models only)	1.) Sprockets out of time SOLUTION: Retime sprockets
Problem	Cause & Solution
Gear reducer dripping oil Note: Some gear reducers are equipped with internal pressure equalizers and do not have external vent plugs.	1.) Shaft seal failure SOLUTION: Replace shaft seal 2.) Vent plug clogged SOLUTION: Clean vent plug 3.) Vent plug in wrong position SOLUTION: Reposition vent plug 4.) Shipping plug was not replaced with vent plug during installation SOLUTION: Remove shipping plug and replace with vent plug 5.) Gear reducer oil overfull SOLUTION: Remove excess oil

7: Preventative Maintenance Schedule

Service Interval	Component	Maintenance Inspection	
weekly	Complete unit	Visual inspection: - All components in place - No apparent damage	
monthly	Chain	See lubrication instructions	
monthly	Belt	Check: - Belt tension - General condition & cleanliness - Seams	
monthly	Drive unit	Check for: - Excessive heat - Dripping oil from gear reducer - Loose fasteners Insure that guards are in place	
semi-annual	Chain	Remove chain cover Check: - Chain tension - Condition of chain guide strips - Sprocket alignment & wear Lubricate chain	
semi-annual	Belt	Check: - Belt tension - General condition and cleanliness - Seams - Grommets - Attachment links - Nylon bushings	
semi-annual	Drive	Check for: - Excessive heat & vibration - Dripping oil from gear reducer - Loose fasteners Check: - Sprocket alignment & wear - Chain tension & lubrication - Lube levels in gear reducer	
semi-annual	Rollers	Check: - Free movement of rollers - Clean & free of foreign matter - End roll set screws Grease bearings if regreaseable	

Note: The above Preventative Maintenance Schedule is based on a conveyor operating 40 hours per week in clean conditions. The frequency of maintenance will depend upon the load, belt speed, time in operation and environmental conditions.

Note for new conveyors: The first semi-annual maintenance check should be performed after the first 40 hours of operation.

8. Recommended Spare Parts List for Belt Merge Conveyors

Listed below are the Spare Parts we recommend be stocked for 1-5 Portec Flomaster® Belt Merge conveyors. By utilizing genuine Portec Flomaster spare parts, you can be assured that these components are proper for your particular unit's continual operation and are backed by the full Portec Flomaster warranty. When ordering, please state model and serial numbers to insure accuracy in parts replacement. We ship EXW Canon City, CO, Net 30 days.

NOTE: Model and Serial Numbers of unit are located on the metal identification plate on the side of the conveyor frame.

Recommended Quantity	Portec Item Number	Description
1	DC2*	Belt assembly with chain
2	DC4**	Special connecting link
10	DC5**	Special attachment link
10	DC6**	Rivet & washer set
10	DC7**	Nylon bushing
10	DC8**	Grommet
1	DC9	End roll; includes taper lock hubs
1	DC10***	End roll sprocket; drive end
1	DC11	End roll bearing; drive end
1	DC12	End roll shaft; drive end
1	DC13	Return roll assembly
1	DC14	Return roll; straight roller with bearings
1	DC21	End roll sprocket assembly; non-drive end
1	DC25	End roll bearing; non-drive for take-up frame
1	DC28	Chain guide strips; complete set

* Standard replacement belts are unlaced at end to allow belt to be cut to fit.
(Lacing provided for users to install.)

** These parts are universal on all sizes

*** Double chain merge must replace in matched pairs

9. Spare Parts List

Conveyor Model: No. _____		
Serial No. _____		
Item #	Description	Part #
DC2	Belt assembly with chain; complete unit ready for replacement with installation of lacing (supplied)	
DC3CT	Chain breaker tool	190129
DC4	Special connecting link #50 chain	020238
DC5	Special attachment link #50 chain	020229
DC6	Rivet and washer set	190254
DC7	Nylon bushing	080020
DC8	Grommet set	190130
DC9	End roll; includes taper lock hubs	
DC10	End roll sprockets; drive end; 50B30 x 1-15/16 ID (Double chain merge must replace in matched pairs)	950147
DC11	End roll bearing; drive end; 4 bolt flange 1-15/16 ID	
DC12	End roll shaft; drive 1-15/16 OD	
DC13	Return roll assembly; includes shaft, bearings & rolls	
DC14	Straight return roll with bearings; (1.9 OD x 15 with 7/16 hex bore)	140055
DC15	Return roll shaft; 7/16 hex	
DC17	Bed idler roll; includes bearings	
DC19	Bed idler roll shaft	
DC21	End roll sprocket assembly; non-drive end includes 50B30 sprocket, 2 ea. thrust washers, 2 ea. shaft collars and sleeve bearing	601625
DC22	End roll sprocket sleeve bearing; non-drive end	010880
DC23	End roll sprocket thrust bearing; non-drive end	010881
DC24	End roll sprocket shaft collar; non-drive end	190946
DC25	End roll bearing; non-drive end; for take-up unit 1-15/16 ID	010881
DC26	End roll bearing take-up frame; non-drive end	010887
DC27	End roll shaft; non-drive; 1-15/16 OD	
DC28	Chain guide strip set; complete upper and lower	

10. Illustrated Parts Diagram

CDC Double Chain Belt Merge Conveyor

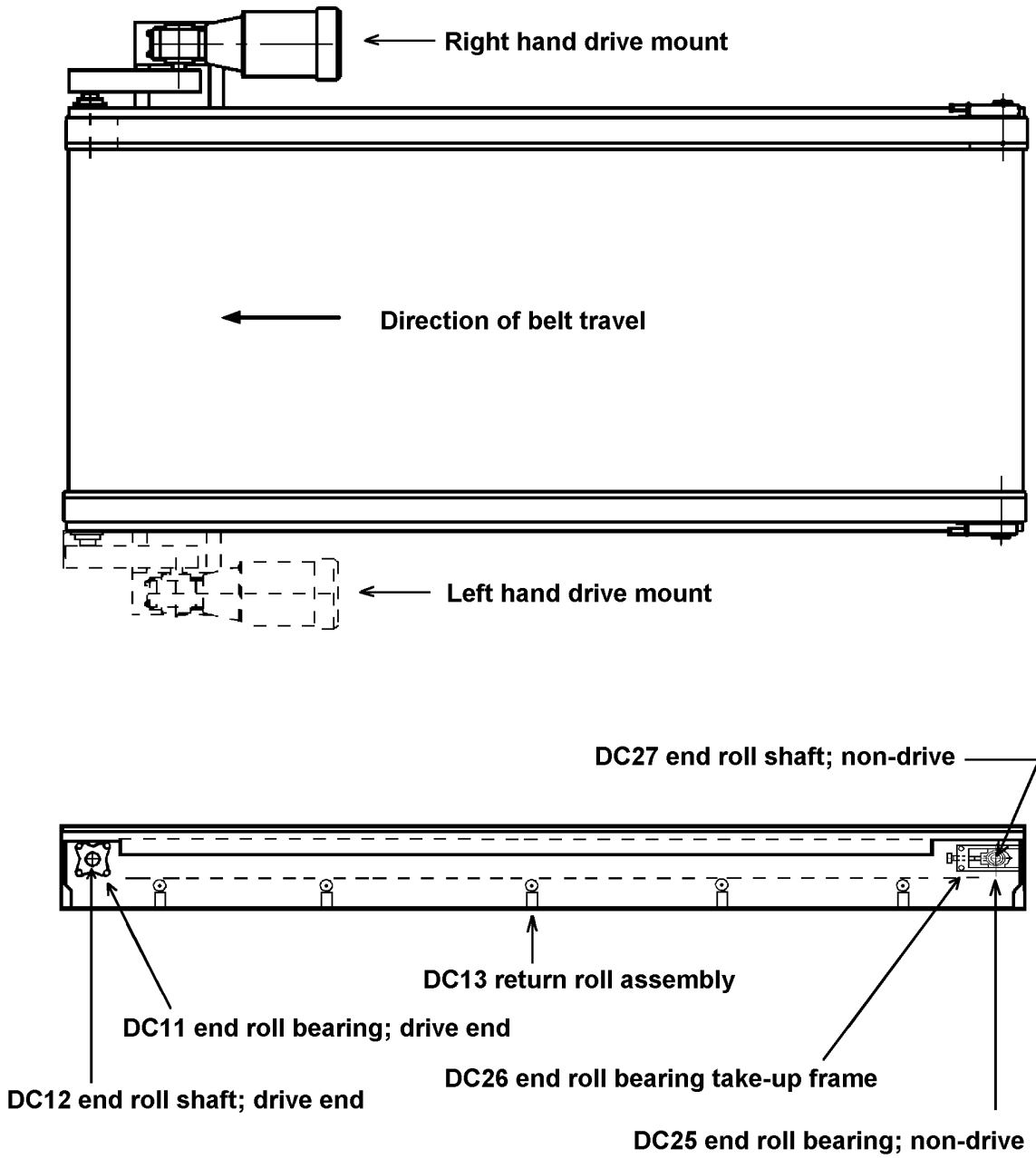

10a. Illustrated Parts Diagram

CSC Single Chain Belt Merge Conveyor

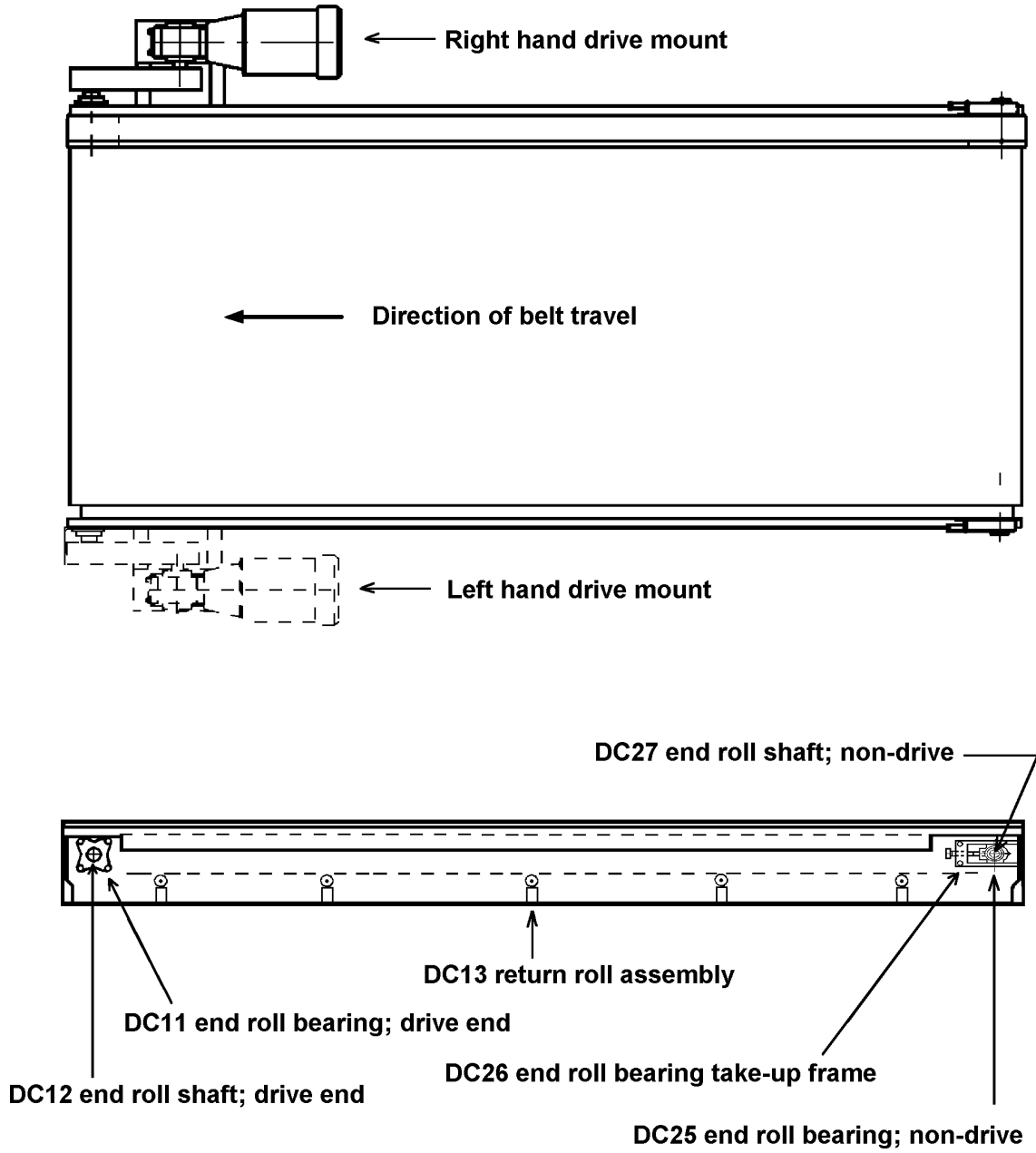

10b. Illustrated Parts Diagram

Section view of End Roll (drive end) on Double Chain Model

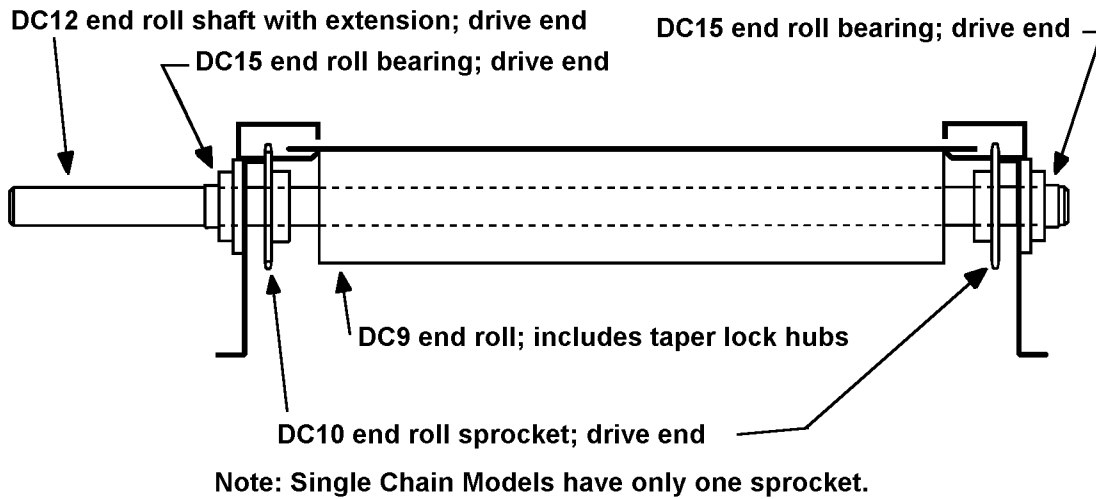

Section view of Retrun Roll on Double Chain Model

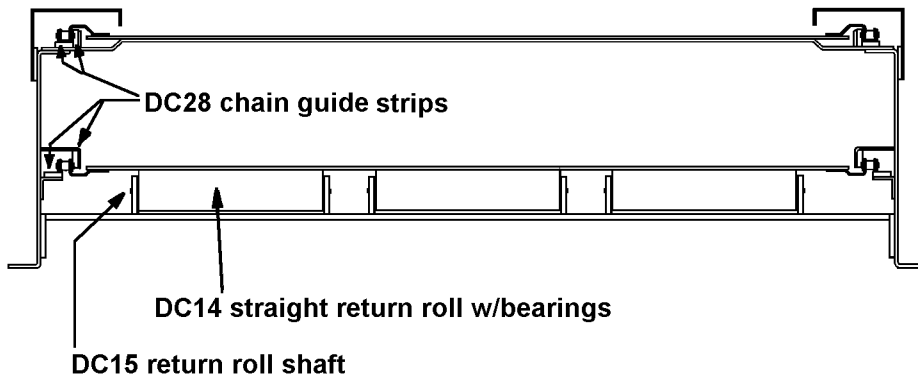

Note: Single Chain Models have chain guide strips only on one side.

10c. Illustrated Parts Diagram

End Roll Sprocket; Drive End

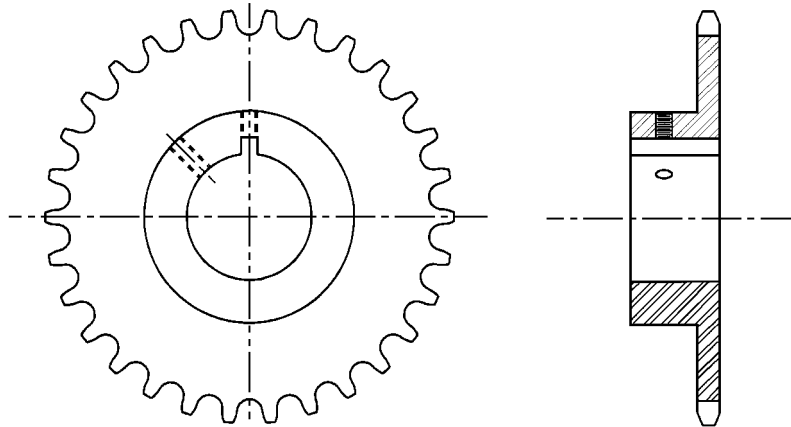

Note: Drive end sprockets for Double Chain Models must be replaced as matched pairs.

End Roll Sprocket; Non-drive End

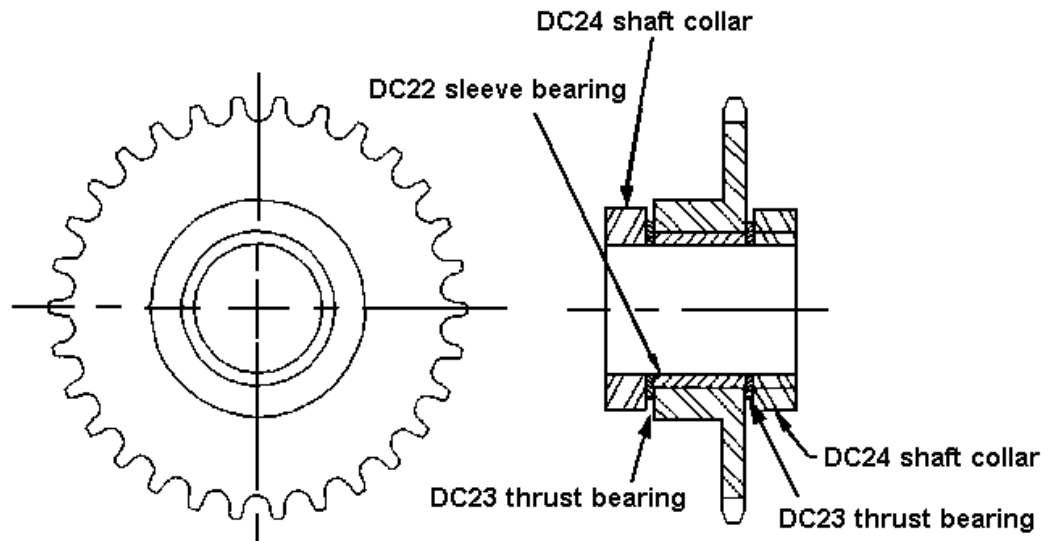

10d. Illustrated Parts Diagram

Belt Hardware

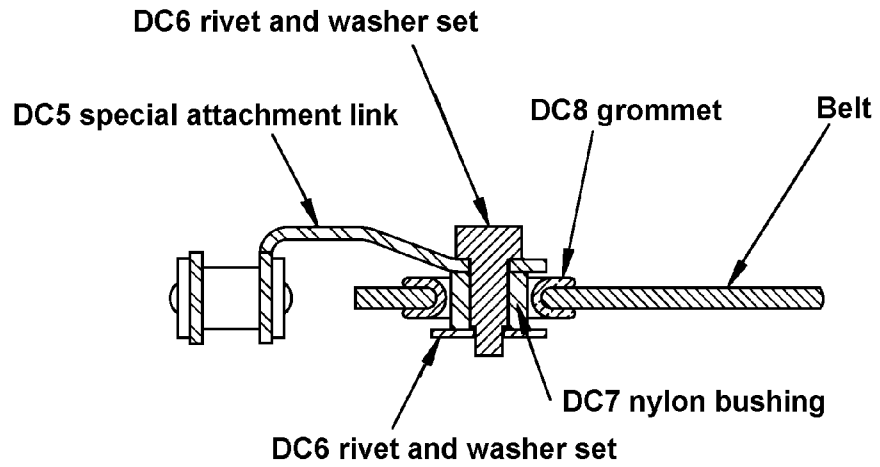

TERMS AND CONDITIONS

VALIDITY – Quotations shall be considered current if outstanding no more than thirty (30) days from date of quotation, unless otherwise stated on quotation.

FREIGHT POLICY – Shipments of products, unless otherwise stated, is EX WORKS PORTEC FLOMASTER'S factory. Written claims for damage in shipment should be made against the carrier. Written claims for shortages should be made against the carrier, specifically if there is evidence of shipping carton/container damage and/or if according to the shipping records there is a discrepancy in numbers of containers shipped versus numbers received.

Only in a situation where the container(s) shipped have been received in good condition, checked for physical content, and signed for verification within three days of delivery, and if such shortage has been found, and if PORTEC FLOMASTER® is notified in writing within 10 days upon receipt of order, PORTEC FLOMASTER will establish that there was or was not a shortage. If a shortage is determined, PORTEC FLOMASTER will provide the customer with the product/parts at PORTEC FLOMASTER'S expense and shall ship F.O.B. as stated in the freight policy. If no shortage is determined, or if others than PORTEC FLOMASTER caused the shortage, the claim shall be deemed invalid and it shall be the responsibility of the customer to arrange payment to PORTEC FLOMASTER to fill the requirements of the deficiency.

PRICE ACCEPTANCE – The prices quoted herein are based on the quantities specified. Any change in quantities may affect quoted price. All orders are subject to acceptance at PORTEC FLOMASTER'S factory. Any expense incurred by PORTEC FLOMASTER as a result of cancellation or the making of any change will be included in PORTEC FLOMASTER'S invoice unless prior waiver of such expense is obtained from PORTEC FLOMASTER.

SHIPMENTS – Quoted Shipment dates are subject to change, without liability for delays beyond PORTEC FLOMASTER'S control.

TERMS OF PAYMENT – Invoices are payable net cash 30 days, unless otherwise noted. There will be an interest charge of 1-1/2% per month for all payments received after 35 days. International (**except Canada**) orders are shipped against confirmed irrevocable letters of credit. All payments shall be in U.S. dollars. If the financial responsibility of a purchaser becomes impaired or is unsatisfactory, or if credit is not established, PORTEC FLOMASTER reserves the right to request payment in advance or satisfactory guarantee that invoices will be paid promptly when due.

QUALITY ASSURANCE – All of its manufactured products are subject to PORTEC FLOMASTER'S Warranty for material and workmanship.

GENERAL – Terms conditions, and product specifications are subject to change without further obligation to PORTEC FLOMASTER.

LIMITED WARRANTY ON NEW EQUIPMENT – PORTEC FLOMASTER provides a Limited Warranty that warrants the material and workmanship of its manufactured products, with exceptions noted, for a period for 24 months beginning one month from the date of shipment from PORTEC FLOMASTER'S factory, according to recorded serial numbers.

Within the stated warranty period, any material or workmanship showing defects will be repaired or replaced,

provided PORTEC FLOMASTER is given written notice within 30 days after failure, and a willingness is expressed to submit the product to PORTEC FLOMASTER, and if PORTEC FLOMASTER authorizes the return of the product, and the product is returned. This warranty does not cover against normal wear of parts or materials. Warranty parts are supplied via EX WORKS PORTEC FLOMASTER'S factory and unless PORTEC FLOMASTER makes express agreement the purchaser shall bear the expense of installation. PORTEC FLOMASTER reserves the right at any time to supervise or install any part of replacement, or supervise adjustment incident to satisfactory operation of equipment. *A possible Warranty PO for parts and/or service may be required prior to shipping parts or exercising warranty labor.*

ITEMS IDENTIFIED AS COMPONENT AND REPLACEMENT PARTS – will be warranted for a period of one (1) year from the date of shipment from the PORTEC FLOMASTER Factory. This warranty on parts will cover only defects in workmanship or material. The warranty *does not cover the costs of the installation of such parts unless authorized by the designated PORTEC FLOMASTER representative.*

Unauthorized returns, modifications, additions or variations, from procedures and information contained in PORTEC FLOMASTER'S Owner's Manuals, and Product Data bulletins, or any misuse, negligence, accident, product jam, or loading beyond rated capacity invalidates this warranty.

EXCEPTIONS:

1. Because of varying operating conditions, all belting supplied will necessarily be subject to manufacturers', warranty rather than that of PORTEC FLOMASTER.
2. Some OEM equipment including motors and gear reducers will be subject to the manufacturer's warranty, not PORTEC FLOMASTER'S. PORTEC FLOMASTER Customer & Product Support will provide assistance in contacting the proper manufacturer's representative. If a replacement is provided from PORTEC FLOMASTER stock, a Possible Warranty PO must be provided. If the warranty is deemed invalid and PORTEC FLOMASTER is not reimbursed for the warranty claim, the PO will be exercised.
3. PORTEC FLOMASTER further reserves the right to void its warranty where final destination and specific application are withheld; product is improperly installed or maintained by others; product is modified without the consent from the designated PORTEC FLOMASTER service representative; product is improperly protected against hazards and adverse environmental conditions during storage prior to or during installation; and/or product is used for applications/conditions other than indicated upon placement of order.

The foregoing warranty is exclusive and in lieu of all other warranties whether written, oral, or implied (including any warranty of merchantability or fitness for any purpose). Under no circumstances shall PORTEC FLOMASTER be liable for incidental or consequential damages. The foregoing warranty cannot be changed except by written authorization signed by an authorized PORTEC FLOMASTER representative, and no attempt to repair or promise to repair or improve PORTEC FLOMASTER products by any other representative of PORTEC FLOMASTER shall change or extend said warranty in any manner whatsoever.